

FLIGHT MANUAL

Doc. n° 2002/28

1st edition, March 29th 2004

1st revision, August 3rd 2005

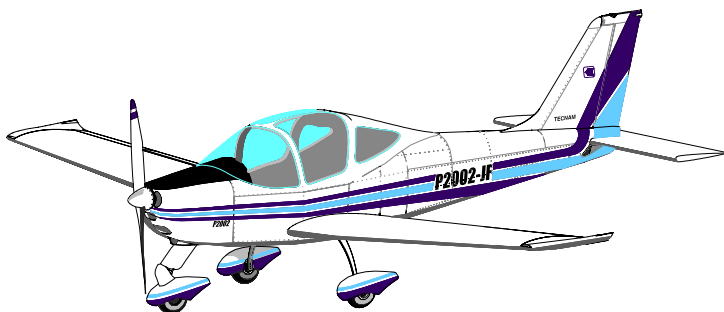

P2002-JF

MANUFACTURER: **COSTRUZIONI AERONAUTICHE TECNAM S.r.l.**

AIRCRAFT MODEL: **P2002-JF**

EASA TYPE CERTIFICATE NO. **A .006**

SERIAL NUMBER: **073**

BUILD YEAR: **2007**

REGISTRATION MARKINGS: **S5-DKD**

This manual contains information to be furnished to the pilot as required by EASA in addition to further information supplied by the manufacturer.

This manual must always present on board the aircraft

The aircraft is to be operated in compliance with information and limitations contained herein.

Sections 2, 3, 4, 5 and 9 (supp.1) are approved by EASA n°EASA.AC.01372 dated 3/8/2005

LIST OF EFFECTIVE PAGES

Sect.	Page	Date	Sect.	Page	Date	
0	i-1	3 August 2005		3-4	29 March 2004	
	i-2	“		3-5	“	
	i-3	“		3-6	“	
	i-4	29 March 2004		3-7	“	
	i-5	“		3-8	“	
	i-6	“		3-9	“	
1	1-1	29 March 2004		3-10	“	
	1-2	“		4	4-1	29 March 2004
	1-3	“			4-2	“
	1-4	“			4-3	“
	1-5	“	4-4		“	
	1-6	3 August 2005	4-5		3 August 2005	
	1-7	29 March 2004	4-6		29 March 2004	
	1-8	“	4-7		“	
	1-9	“	4-8		“	
	1-10	“	4-9		3 August 2005	
	1-11	“	4-10		29 March 2004	
	1-12	“	4-11		“	
2	2-1	29 March 2004	4-12		“	
	2-2	“	5	5-1	29 March 2004	
	2-3	“		5-2	“	
	2-4	3 August 2005		5-3	“	
	2-5	29 March 2004		5-4	“	
	2-6	3 August 2005		5-5	“	
	2-7	29 March 2004		5-6	3 August 2005	
	2-8	“		5-7	29 March 2004	
	2-9	“		5-8	“	
	2-10	“		5-9	“	
	2-11	3 August 2005		5-10	“	
	2-12	29 March 2004		5-11	“	
3	3-1	29 March 2004		5-12	“	
	3-2	“	5-13	“		
	3-3	“	5-14	“		

Sect.	Page	Date	Sect.	Page	Date
6	6-1	29 March 2004	9	9-1	29 March 2004
	6-2	“		9-2	“
	6-3	“		9-3	“
	6-4	“		9-4	“
	6-5	“		9-5	“
	6-6	“		9-6	“
	6-7	“			
	6-8	“			
	6-9	“			
	6-10	“			
	6-11	“			
	6-12	“			
	6-13	“			
	6-14	“			
7	7-1	29 March 2004			
	7-2	“			
	7-3	“			
	7-4	“			
	7-5	“			
	7-6	“			
	7-7	“			
	7-8	“			
	7-9	“			
	7-10	“			
	7-11	“			
	7-12	“			
8	8-1	29 March 2004			
	8-2	“			
	8-3	“			
	8-4	“			

TABLE OF CONTENTS

General	Section 1
Limitations	Section 2*
Emergency Procedures	Section 3*
Normal Procedures	Section 4*
Performances	Section 5**
Weight & Balance / Equipment List	Section 6
Systems	Section 7
Ground Handling, Servicing and Maintenance	Section 8
Supplements	Section 9*

* Section approved by EASA

** Section partially approved by EASA

INTENTIONALLY LEFT BLANK

SECTION 1

GENERAL

TABLE OF CONTENTS

INTRODUCTION	2
CERTIFICATION BASIS	2
WARNINGS - CAUTIONS - NOTES	2
THREE-VIEW DRAWING	3
DESCRIPTIVE DATA	4
CONTROL SURFACES TRAVEL LIMITS	4
ENGINE	5
PROPELLER	5
FUEL	6
OIL SYSTEM	6
COOLING	6
MAXIMUM WEIGHTS	7
STANDARD WEIGHTS	7
SPECIFIC LOADINGS	7
ABBREVIATIONS AND TERMINOLOGY	8
UNIT CONVERSION CHART	11

INTRODUCTION

The **P2002-JF** is a twin seat, single engine aircraft with a tapered, low wing, fixed main landing gear and steerable nosewheel.

This Flight Manual has been prepared to provide pilots and instructors with information for the safe and efficient operation of this very light aeroplane.

This manual includes the material required to be furnished to the pilot of CS-VLA. It also contains supplemental data supplied by aeroplane manufacturer.

CERTIFICATION BASIS

This type of aircraft has been approved by the European Safety Aviation Agency in accordance with CS-VLA of 14 November 2003, and the Type Certificate No. A.006 issued on 27th May 2004.

Category of Airworthiness: Normal

Noise Certification Basis: EASA CS-36 1st edition dated 17th October 2003, with reference to ICAO/Annex 16 3rd edition dated 1993, Vol.1 Chapter 10.

WARNINGS - CAUTIONS - NOTES

The following definitions apply to warnings, cautions and notes used in the Flight Manual.

WARNING

Means that the non-observation of the corresponding procedure leads to an immediate or important degradation of the flight safety.

CAUTION

Means that the non-observation of the corresponding procedure leads to a minor or to a more or less long term degradation of the flight safety.

NOTE

Draws the attention to any special item not directly related to safety but which is important or unusual.

THREE-VIEW DRAWING

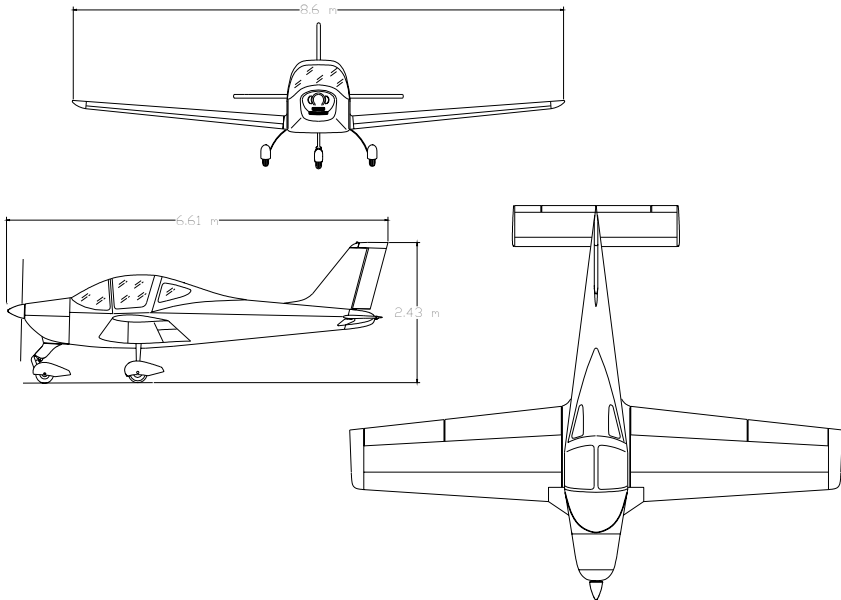

NOTE

- Dimensions shown refer to aircraft weight of 580 kg and normal operating tire pressure.
- Propeller ground clearance 320mm
- Propeller ground clearance with deflated front tire and nosewheel shock absorber compressed by 102mm
- Minimum ground steering radius 5.5m

DESCRIPTIVE DATA

WING

Wing span:	8.6 m
Wing surface	11.5 m ²
Wing loading	50.4 kg/m ²
Aspect ratio	6.4
Taper ratio	0.6
Dihedral	5°

FUSELAGE

Overall length	6.61 m
Overall width	1.11 m
Overall height	2.43 m

EMPENNAGE

Stabilator span	2.90 m
Vertical tail span	1.10 m

LANDING GEAR

Wheel track:	1.85 m
Wheel base:	1.62 m
Main gear tires: Air Trac	5.00-5
Wheel hub and brakes: Cleveland	199-102
Nose gear tire: Sava	4.00-6

CONTROL SURFACES TRAVEL LIMITS

Ailerons	Up 20° down 15 ° ± 2°
Stabilator	Up 15° down 3° ± 1°
Trim-Tab	2° ; 9° ± 1°
Rudder	RH 30° LH 30° ± 2°
Flaps	0°; 40° ± 1°

ENGINE

Manufacturer:	Bombardier-Rotax GmbH
Model	912 S2
Certification basis	FAR 33 Amendment 15
Austrian T.C. No.	TW 9-ACG dated 27 th November 1998
Type:	4 cylinder horizontally-opposed twins with overall displacement of 1352 c.c., mixed cooling, (water-cooled heads and air-cooled cylinders), twin carburetors, integrated reduction gear with torque damper.
Maximum power:	73.5 kW (98.5 hp) @ 5800 rpm (max. 5') 69.0 kW (92.5 hp) @ 5500 rpm (cont.)

PROPELLER

Manufacturer:	Hoffmann Propeller
Certification Basis	CAR Part 14
Type Certificate No.	SO/E 30 dated 10 December 1999
Model:	HO17GHM A 174 177 C
Number of blades:	2
Diameter:	1740 mm (no reduction permitted)
Type:	Fixed pitch – wood

FUEL

Fuel grade:	<ul style="list-style-type: none">• Min. RON 95• EN 228 Premium• EN 228 Premium plus• AVGAS 100LL (see Section 2 page 11)
Fuel tanks:	2 wing tanks integrated within the wing's leading edge. Equipped with finger strainers outlet and with drain fittings.
Capacity of each wing tank	50 liters
Total capacity:	100 liters
Total usable fuel	99 litres

OIL SYSTEM

Oil system type:	Forced, with external oil reservoir
Oil:	Lubricant specifications and grade are detailed into the "Rotax Operator's Manual" and in its related documents.
Oil Capacity:	Max. 3.0 litres – min. 2.0 liters

COOLING

Cooling system:	Mixed air and liquid pressurized closed circuit system
Coolant:	Coolant type and specifications are detailed into the "Rotax Operator's Manual" and in its related documents.

MAXIMUM WEIGHTS

Maximum take-off weight:	580 kg
Maximum landing weight:	580 kg
Maximum baggage weight	20 kg

STANDARD WEIGHTS

Standard Empty Weight	337 kg
Maximum useful load	243 kg

SPECIFIC LOADINGS

Wing Loading	50.4 kg/m ²
Power Loading	5.9 kg/hp

ABBREVIATIONS AND TERMINOLOGY

GENERAL AIRSPEED TERMINOLOGY AND SYMBOLS

KCAS	<u>Calibrated Airspeed</u> is the indicated airspeed corrected for position and instrument error and expressed in knots.
KIAS	<u>Indicated Airspeed</u> is the speed shown on the airspeed indicator and expressed in knots.
KTAS	<u>True Airspeed</u> is the airspeed expressed in knots relative to undisturbed air which is KCAS corrected for altitude and temperature.
V _{FE}	<u>Maximum Flap Extended Speed</u> is the highest speed permissible with wing flaps in a prescribed extended position.
V _{NO}	<u>Maximum Structural Cruising Speed</u> is the speed that should not be exceeded except in smooth air, then only with caution.
V _{NE}	<u>Never Exceed Speed</u> is the speed limit that may not be exceeded at any time.
V _S	<u>Stalling Speed.</u>
V _{S0}	<u>Stalling speed in landing configuration</u>
V _{S1}	<u>Stalling speed in clean configuration (flap 0°)</u>
V _X	<u>Best Angle-of-Climb Speed</u> is the speed which results in the greatest gain of altitude in a given horizontal distance.
V _Y	<u>Best Rate-of-Climb Speed</u> is the speed which results in the greatest gain in altitude in a given time.
V _R	<u>Rotation speed:</u> is the speed at which the aircraft rotates about the pitch axis during takeoff
V _{LO}	<u>Lift off speed:</u> is the speed at which the aircraft generally lifts off from the ground.
V _{obs}	<u>Obstacle speed:</u> is the speed at which the aircraft flies over a 15m obstacle during takeoff or landing

METEOROLOGICAL TERMINOLOGY

- OAT** Outside Air Temperature is the free air static temperature expressed in degrees Celsius (°C).
- T_S** Standard Temperature is 15°C at sea level pressure altitude and decreased by 2°C for each 1000 ft of altitude.
- H_p** Pressure Altitude is the altitude read from an altimeter when the barometric subscale has been set to 1013 mb.

ENGINE POWER TERMINOLOGY

- RPM** Revolutions Per Minute: is the number of revolutions per minute of the propeller, multiplied by 2.4286 yields engine RPM.

AIRPLANE PERFORMANCE AND FLIGHT PLANNING TERMINOLOGY

- Crosswind Velocity* is the velocity of the crosswind component for which adequate control of the airplane during takeoff and landing is guaranteed.
- Usable fuel* is the fuel available for flight planning.
- Unusable fuel* is the quantity of fuel that cannot be safely used in flight..
- g* is the acceleration of gravity.
- TOR* is the takeoff distance measured from actual start to wheel liftoff point
- TOD* is total takeoff distance measured from start to 15m obstacle clearing
- GR* is the distance measured during landing from actual touchdown to stop point
- LD* is the distance measured during landing, from 15m obstacle clearing to actual stop.
- S/R* is specific range, that is, the distance (in nautical miles) which can be expected at a specific power setting and/or flight configuration per kilo of fuel used.

WEIGHT AND BALANCE TERMINOLOGY

<i>Datum</i>	“Reference datum” is an imaginary vertical plane from which all horizontal distances are measured for balance purposes.
<i>Arm</i>	is the horizontal distance from the reference datum to the center of gravity (C.G.) of an item.
<i>Moment</i>	is the product of the weight of an item multiplied by its arm.
<i>C. G.</i>	<u>Center of Gravity</u> is the point at which the airplane, or equipment, would balance if suspended. Its distance from the reference datum is found by dividing the total moment by the total weight of the airplane.
<i>Empty Weight</i>	<u>Empty Weight</u> is the weight of the aeroplane with engine fluids and oil at operating levels.
<i>Useful Load</i>	is the difference between takeoff weight and the basic empty weight.
<i>Maximum Takeoff Weight</i>	is the maximum weight approved for the start of the takeoff run.
<i>Maximum Landing Weight</i>	is the maximum weight approved for the landing touch down.
<i>Tare</i>	is the weight of chocks, blocks, stands, etc. used when weighing an airplane, and is included in the scale readings. Tare is deducted from the scale reading to obtain the actual (net) airplane weight.

UNIT CONVERSION CHART

MULTIPLYING		BY →	YIELDS	
TEMPERATURE				
Fahrenheit	[°F]	$\frac{5}{9} \cdot (F - 32)$	Celsius	[°C]
Celsius	[°C]	$\left(\frac{9}{5} \cdot C\right) + 32$	Fahrenheit	[°F]
FORCES				
Kilograms	[kg]	2.205	Pounds	[lbs]
Pounds	[lbs]	0.4536	Kilograms	[kg]
SPEED				
Meters per second	[m/s]	196.86	Feet per minute	[ft/min]
Feet per minute	[ft/min]	0.00508	Meters per second.	[m/s]
Knots	[kts]	1.853	Kilometres / hour	[km/h]
Kilometres / hour	[km/h]	0.5396	Knots	[kts]
PRESSURE				
Atmosphere	[atm]	14.7	Pounds / sq. in	[psi]
Pounds / sq. in	[psi]	0.068	Atmosphere	[atm]
LENGTH				
Kilometers	[km]	0.5396	Nautical miles	[nm]
Nautical miles	[nm]	1.853	Kilometers	[km]
Meters	[m]	3.281	Feet	[ft]
Feet	[ft]	0.3048	Meters	[m]
Centimeters	[cm]	0.3937	Inches	[in]
Inches	[in]	2.540	Centimeters	[cm]
VOLUME				
Liters	[l]	0.2642	U.S. Gallons	[US Gal]
U.S. Gallons	[US Gal]	3.785	Liters	[l]
AREA				
Square meters	[m ²]	10.76	Square feet	[sq ft]
Square feet	[sq ft]	0.0929	Square meters	[m ²]

INTENTIONALLY LEFT BLANK

SECTION 2

LIMITATIONS

TABLE OF CONTENTS

INTRODUCTION.....	2
AIRSPED LIMITATIONS	2
AIRSPED INDICATOR MARKINGS.....	3
POWERPLANT LIMITATIONS	4
LUBRICANT	5
COOLANT.....	6
PROPELLER	6
POWERPLANT INSTRUMENT MARKINGS	7
OTHER INSTRUMENT MARKINGS.....	7
WEIGHTS.....	8
CENTER OF GRAVITY RANGE.....	8
APPROVED MANEUVERS	9
MANEUVERING LOAD FACTOR LIMITS	9
FLIGHT CREW	10
KINDS OF OPERATION	10
FUEL.....	11
MAXIMUM PASSENGER SEATING	11
DEMONSTRATED CROSS WIND SAFE OPERATIONS	11
LIMITATION PLACARDS.....	12

INTRODUCTION

Section 2 includes operating limitations, instrument markings, and basic placards necessary for safe operation of the **P2002-JF**, its engine and standard systems and equipment.

AIRSPED LIMITATIONS

Airspeed limitations and their operational significance are shown below:

SPEED		KIAS	KCAS	REMARKS
V_{NE}	Never exceed speed	138	135	Never exceed this speed in any operation.
V_{NO}	Maximum Structural Cruising Speed	110	106	Never exceed this speed unless in smooth air, and then only with caution.
V_A	Manoeuvring speed	96	94	Do not make full or abrupt control movements above this speed as this may cause stress in excess of limit load factor
V_{FE}	Maximum flap extended speed	67	69	Never exceed this speed for any flap setting.

AIRSPPEED INDICATOR MARKINGS

Airspeed indicator markings and their colour code are explained in the following table.

Refer to section 9 of this Flight Manual for operational limitations for aircraft fitted with optional equipment.

MARKING	KIAS (knots)	SIGNIFICANCE
White arc	26 - 67	Positive Flap Operating Range (lower limit is V_{SO} , at maximum weight and upper limit is the maximum speed permissible with flaps extension)
Green arc	39 - 110	Normal Operating Range (lower limit is V_{S1} at maximum weight and most forward c.g. with flaps retracted and upper limit is maximum structural speed V_{NO}).
Yellow arc	110 - 138	Manoeuvres must be conducted with caution and only in smooth air.
Red line	138	Maximum speed for all operations.

POWERPLANT LIMITATIONS

The following table lists operating limitations for aircraft installed engine:

ENGINE MANUFACTURER: Bombardier Rotax GmbH.

ENGINE MODEL: 912 S2

MAXIMUM POWER: (see table below)

	Max Power kW (<i>hp</i>)	Max rpm. rpm prop.(<i>engine</i>)	Time max. (min.)
Max.	73.5 (98.5)	2388 (5800)	5
Max cont.	69 (92.5)	2265 (5500)	-

NOTE

With full throttle, at fixed point in no wind conditions, the maximum propeller's rpm should be 2100 ± 100.

TEMPERATURES:

Max cylinder heads	135° C
Max. / min. Oil	50° C / 130° C
Oil normal operating temperature (approx.)	90° C – 110° C

OIL PRESSURE:

Min	0.8 bar	(below 1400 rpm prop.)
Normal	2.0 - 5.0 bar	(above 1400 rpm prop.)

ENGINE START, OPER. TEMP:

OAT Min	-25° C
OAT Max	+50° C

1st revision, August 3rd 2005

WARNING

Admissible pressure for cold start is 7 bar maximum for short periods.

FUEL PRESSURE:

Min 2.2 psi (0.15 bar)
Max 5.8 psi (0.40 bar)

LUBRICANT

VISCOSITY

Use viscosity grade oil as specified in the following table:

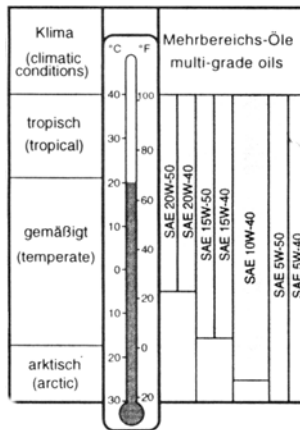

WARNING

Use of Aviation Grade Oil with or without additives is not permitted

COOLANT

Coolant type and specifications are detailed into the “Rotax Operator’s Manual” and in its related documents.

PROPELLER

MANUFACTURER: Hoffmann Propeller GmbH

MODEL: HO17GHM A 174 177 C

PROPELLER TYPE: Wood twin blade fixed pitch

DIAMETER: 1740 mm (no reduction permitted)

POWERPLANT INSTRUMENT MARKINGS

Powerplant instrument markings and their colour code significance are shown below:

INSTRUMENT		RED LINE Minimum limit	GREEN ARC Normal operating	YELLOW ARC Caution	RED LINE Maximum limit
Prop. tach	rpm	----	580 - 2265	2265 - 2388	2388
Oil Temp.	°C	50	90 - 110	50 - 90 110 - 130	130
Cylinder heads temp.	°C	----	0 - 135	----	135
Oil pressure	bar	0.8	2 - 5	0.8 - 2 5 - 7 ⁽¹⁾	7
Fuel press.	psi	2.2	2.2 - 5.8	----	5.8
Fuel q.ty	litres	---- ⁽²⁾	----	----	----

OTHER INSTRUMENT MARKINGS

INSTRUMENT	RED LINE Minimum limit	GREEN ARC Normal operating	YELLOW ARC Caution	RED LINE Maximum limit
Voltmeter	10 Volt	12 - 14 Volt	----	----
Suction gage	4.0 in. Hg	4.5 - 5.5 in. Hg	----	----

¹ Admissible pressure for cold start is 7 bar maximum for short periods.

² The unusable fuel quantity for each tank is 0.5 litres

WEIGHTS

Maximum takeoff weight: 580 kg

Maximum landing weight: 580 kg

Maximum zero fuel weight: 580 kg

Maximum baggage weight: 20 kg (2.26m aft from datum)

CENTER OF GRAVITY RANGE

Datum	Propeller support flange without spacer
Ref. for levelling	Seat track supporting trusses (ref. to sect.6 for the procedure)
Forward limit	1.693 m (26.0% MAC) aft of datum for all weights
Aft limit	1.782 m (32.5% MAC) aft of datum for all weights

WARNING

It is the pilot's responsibility to insure that the airplane is properly loaded. Refer to section 6 for appropriate instructions.

APPROVED MANEUVERS

This aircraft is certified in normal category under EASA CS-VLA.

CS-VLA applies to aeroplanes intended for non-aerobatic operation only. Non aerobatic operation includes:

- Any manoeuvre pertaining to “normal” flight
- Stalls (except whip stalls)
- Lazy eights
- Chandelles
- Turns in which the angle of bank is not more than 60°

Acrobatic manoeuvres, including spins, are not approved.

Recommended entry speeds for each approved manoeuvre are as follows:

MANOEUVRE	Speed (KIAS)
Lazy eight	96
Chandelle	110
Steep turn (max 60°)	96
Stall	Slow deceleration (1 kts/s)

WARNING

Limit load factor could be exceeded by moving abruptly flight controls at their end run at a speed above V_A (96 KIAS, Manoeuvring Speed).

MANEUVERING LOAD FACTOR LIMITS

Manoeuvring load factors are as follows:

FLAPS		
0°	+3.8	- 1.9
40°	+1.9	0

FLIGHT CREW

Minimum crew for flight is one pilot seated on the left side.

KINDS OF OPERATION

The airplane, in standard configuration, is approved only for day VFR operation with terrain visual contact. Minimum equipment required is as follows:

- Altimeter
- Airspeed Indicator
- Heading Indicator
- Fuel Gauges
- Oil Pressure Indicator
- Oil Temp. Indicator
- Cylinder Heads Temp. Indicator
- Outside Air Temp. indicator
- Tachometer
- Chronometer
- First Aid Kit
- Hand-held fire extinguisher
- Emergency hammer

For further standard equipment refer to section 6.

Flight into expected and/or known icing conditions is prohibited.

NOTE

Additional equipments may be asked to fulfill national or specific requirements. It's a responsibility of the continued airworthiness manager to be compliant with these requirements.

FUEL

TWO TANKS: 50 liters each

TOTAL FUEL CAPACITY: 100 liters

USABLE FUEL Q.TY: 99 litres

UNUSABLE FUEL Q.TY: 0.5 litres each (1.0 litres total)

Compensate uneven fuel tank levels by acting on the fuel selector valve located into the cabin.

APPROVED FUEL

- * Min. RON 95
- * EN 228 Premium
- * EN 228 Premium plus
- * AVGAS 100LL (see *Warning* below)

WARNING

Prolonged use of Aviation Fuel Avgas 100LL results in greater wear of valve seats and greater combustion deposits inside cylinders due to higher lead content. It is therefore suggested to avoid using this type of fuel unless strictly necessary.

MAXIMUM PASSENGER SEATING

With the exception of the pilot, only **one** passenger is allowed on board of this aircraft.

DEMONSTRATED CROSS WIND SAFE OPERATIONS

The aircraft controllability during take-offs and landings has been demonstrated with a cross wind components of 22 kts.

1st revision, August 3rd 2005

LIMITATION PLACARDS

The following limitation placards must be placed in plain view on the aircraft. Near the airspeed indicator a placard will state the following:

MANEUVERING SPEED $V_A=96$ KIAS

On the left hand side of the dashboard a placard will state the following:

THIS AIRPLANE IS CLASSIFIED AS A VERY LIGHT AIRPLANE APPROVED FOR DAY VFR ONLY, IN NON-ICING CONDITIONS. ALL AEROBATIC MANEUVERS INCLUDING INTENTIONAL SPIN ARE PROHIBITED. SEE FLIGHT MANUAL FOR OTHER LIMITATIONS.

NO SMOKING

Near baggage compartment a placard will state the following:

FASTEN TIE-DOWN NET
MAXIMUM WEIGHT 20 kg
MAX. PRESS 12.5 Kg/dm²

On the wing root there is the following placard:

NO STEP

For other placards see Maintenance Manual doc. 2002/30.

SECTION 3

EMERGENCY PROCEDURES

TABLE OF CONTENTS

INTRODUCTION.....	2
ENGINE FAILURES	2
IN-FLIGHT ENGINE RESTART.....	5
SMOKE AND FIRE.....	5
GLIDE.....	6
LANDING EMERGENCY	7
RECOVERY FROM UNINTENTIONAL SPIN	8
OTHER EMERGENCIES.....	8

INTRODUCTION

Section 3 includes checklists and detailed procedures to be used in the event of emergencies. Emergencies caused by a malfunction of the aircraft or engine are extremely rare if appropriate maintenance and pre-flight inspections are carried out.

In case of emergency, suggestions of the present section should be considered and applied as necessary to correct the problem.

Before operating the aircraft, the pilot should become thoroughly familiar with the present manual and, in particular, with the present section. Further, a continued and appropriate training should be provided.

In case of emergency the pilot should act as follows:

1. Keep control of the aeroplane
2. Analyze the situation
3. Apply the pertinent procedure
4. Inform the Air Traffic Control if time and conditions allow.

ENGINE FAILURES

If an emergency arise, the basic guidelines described in this section should be considered and applied as necessary to correct the problem.

ENGINE FAILURE DURING TAKEOFF RUN

1. Throttle: *idle* (fully out)
2. Brakes: *apply as needed*
3. Magnetos: *OFF*.
4. Generator & Master switches: *OFF*.

With the aeroplane under control

5. Fuel selector valve: *OFF*
6. Electric fuel pump: *OFF*

ENGINE FAILURE IMMEDIATELY AFTER TAKEOFF

1. Speed: *check*
2. Find a suitable place on the ground to land safely. The landing should be planned straight ahead with only small changes in directions not exceeding 45° to the left and 45° to the right
3. Flaps: *as needed*.
4. Throttle: *as required*

At touch down

5. Magnetos: *OFF*
6. Generator & Master switches: *OFF*.
7. Fuel selector valve: *OFF*
8. Electric fuel pump: *OFF*

ENGINE FAILURE DURING FLIGHT

IRREGULAR ENGINE RPM

1. Throttle: *check position and adjustable friction*
2. Check engine gauges.
3. Check both fuel quantity indicators.
4. Carburettors heating: *ON*
5. Electric fuel pump: *ON*

If the engine continues to run irregularly:

6. Fuel selector valve: *change the fuel feeding to the tank not in use (e.g. if you are drawing fuel from the LEFT tank, change to RIGHT or v.v.)*

If the engine continues to run irregularly:

7. Land as soon as possible.

LOW FUEL PRESSURE

If the fuel pressure indicator falls below the **2.2 psi** (*0.15 bar*) limit, it is necessary to apply the following procedure:

1. Fuel quantity indicators: *check*
2. Electric fuel pump: *ON*

If the engine continues to run irregularly:

3. Fuel selector valve: *change the fuel feeding to the tank not in use (e.g. if you are drawing fuel from the LEFT tank, change to RIGHT or v.v.)*

If the fuel pressure continues to be low:

4. Land as soon as possible

LOW OIL PRESSURE

1. Check oil temperature: *check*

If the temperature tends to increase:

2. Throttle: *set to reach a speed of 68 KIAS (maximum efficiency speed)*
3. Land as soon as possible and be alert for impending engine fault and consequent emergency landing.

If the temperature remains within the green arc limits:

4. Land as soon as possible

IN-FLIGHT ENGINE RESTART

1. Altitude: *preferably below 4000 ft*
2. Carburettors heating: *ON*
3. Electric fuel pump: *ON*
4. Fuel selector valve: *swap from one tank to another*
5. Throttle: *middle position*
6. Generator & Master switch: *ON*
7. Magnetos: *START*

If the restart attempt fails:

8. Procedure for a forced landing: *apply*

In case of an engine restart:

9. Land as soon as possible.

SMOKE AND FIRE

ENGINE FIRE DURING TAKEOFF

1. Throttle: *idle (fully out)*
2. Brakes: *as necessary*

With the aeroplane under control

3. Fuel selector valve: *OFF*
4. Electric fuel pump: *OFF*
5. Cabin heating: *OFF*
6. Magnetos: *OFF*
7. Generator & Master switch: *OFF*
8. Parking brake: *engage*
9. Escape rapidly from the aircraft.

ENGINE FIRE WHILE PARKED

1. Fuel selector valve: *OFF*
2. Electric fuel pump: *OFF*
3. Magnetos: *OFF*
4. Generator & Master switches: *OFF*
5. Parking brake: *ON*
6. Do not attempt air start.
7. Escape rapidly from the aircraft.

ENGINE FIRE IN-FLIGHT

1. Cabin heating: *OFF*
2. Fuel selector valve: *OFF*
3. Electric fuel pump: *OFF*
4. Throttle: *full in until the engine stops running*
5. Cabin vents: *OPEN*
6. Magnetos: *OFF*
7. Do not attempt an in-flight restart.
8. Procedure for a forced landing: *apply*

CABIN FIRE DURING FLIGHT

1. Cabin heating: *OFF*
2. Cabin vents: *OPEN*
3. Canopy: *open, if necessary*
4. Master switch: *OFF*
5. Try to choke the fire. Direct the fire extinguisher towards flame base
6. Procedure for a forced landing: *apply*

GLIDE

1. Flaps: *retract*
2. Speed: *68 KIAS (maximum efficiency speed)*
3. Electric equipments (*Landing, Strobe & Nav lights*): *OFF*
4. In-flight engine restart: if conditions permit, try to restart several times

NOTE

Glide ratio is 12.8 therefore with 1000ft elevation it is possible to cover ~4 km (~2 nautical miles) in zero wind conditions.

LANDING EMERGENCY

FORCED LANDING WITHOUT ENGINE POWER

1. Procedure to glide: *apply (suggested airspeed 68 KIAS)*
2. Locate most suitable terrain for emergency landing, possibly upwind.
3. Fuel selector valve: *OFF*
4. Electric fuel pump: *OFF*
5. Magnetos: *OFF*
6. Tighten safety belts, canopy locks: *tighten – lock*

When certain to land

7. Flaps: *as necessary*
8. Generator and Master switches: *OFF*.

POWER-ON FORCED LANDING

1. Descent: *set*
2. Flaps: *as necessary*
3. Select terrain area most suitable for emergency landing and flyby checking for obstacles and wind direction.
4. Safety belts, canopy locks: *tighten – lock*

When certain to land

5. Flaps: *as necessary*
6. Fuel selector valve: *OFF*
7. Electric fuel pump: *OFF*
8. Magnetos: *OFF*
9. Generator and Master switches: *OFF*

LANDING WITH A FLAT NOSE TIRE

1. Pre-landing checklist: *complete*
2. Flaps: *land*
3. Land and maintain aircraft *NOSE HIGH* attitude as long as possible.

LANDING WITH A FLAT MAIN TIRE

1. Pre-landing checklist: *complete*
2. Flaps: *land*
3. Land aeroplane on the side of runway opposite to the side with the defective tire to compensate for change in direction which is to be expected during final rolling
4. Touchdown with the GOOD TIRE FIRST and hold aircraft with the flat tire off the ground as long as possible.

RECOVERY FROM UNINTENTIONAL SPIN

If unintentional spin occur, the following recovery procedure should be used:

1. Throttle: *idle (full out position)*
2. Rudder: *full, in the opposite direction of the spin*
3. Stick: *move and hold forward until spin is halted*

As the spin is halted

4. Rudder: *neutralize*
5. Aeroplane attitude: *make a smooth recovery by pulling the stick back gently averting speeds in excess of V_{NE} and maximum load factor ($n=+3.8$)*
6. Throttle: *readjust to restore engine power.*

OTHER EMERGENCIES

UNINTENTIONAL FLIGHT INTO ICING CONDITIONS

1. Carburettor heating: *ON*
2. Get away from icing conditions by changing altitude or direction of flight in order to reach an area with warmer external temperature
3. Controls surfaces: continue to move to maintain their movability
4. Increase rpm to avoid ice formation on propeller blades.
5. Cabin heat: *ON*

WARNING

In case of ice formation on wing leading edge, stall speed may increase.

CARBURETTOR ICE

AT TAKEOFF

At takeoff, given the unlikely possibility of ice formation at full throttle, carburettor heat is normally OFF.

IN FLIGHT

With external temperatures below 15° C, or on rainy days or with humid, cloudy, hazy or foggy conditions or whenever a power loss is detected, turn carburettor heat to ON until engine power is back to normal.

ELECTRIC POWER SYSTEM MALFUNCTION

Electric power supply system malfunctions may be avoided by carrying out inspections as scheduled and prescribed in the Maintenance Manual. Causes for malfunctions are hard to establish but, in any case, problems of this nature must be dealt with immediately. The following may occur:

GENERATOR LIGHT ILLUMINATES

Generator light may illuminate for a faulty alternator or when voltage is above 16V, in this case the over-voltage sensor automatically shuts down the alternator.

In both cases proceed as follows:

1. Generator switch and master switch: *OFF*
2. Generator switch and master switch: *ON*

If the problem persist

3. Generator switch: *OFF*
4. Non vital electric equipments: *OFF*
5. Radio calls: *reduce at the strictly necessary*

NOTE

The battery is capable of supply the electrical system enough time to complete flight in emergency conditions, with normal flight electric-loads including operation of flap and trim.

TRIM SYSTEM FAILURE

LOCKED CONTROL

In case the trim control should not respond, act as follows:

1. Breakers: *check*
2. Trim switch Lh/Rh: *check for correct position*
3. Speed: *adjust to control aircraft without excessive stick force*
4. Land aircraft as soon as possible.

RUNAWAY

If trim position indicator reads displacement without pilot's action on trim control, follow procedure below:

1. Trim power switch: *OFF*
2. Speed: *adjust speed to control aircraft without excessive stick force*
3. Land aircraft as soon as possible.

ESCAPING THROUGH A LOCKED CANOPY

With the engine shut off:

1. Using the emergency hammer to break a canopy's glass.
2. If it is possible, try to enlarge the hole and remove any splinter.

SECTION 4

NORMAL PROCEDURES

TABLE OF CONTENTS

INTRODUCTION.....	2
RIGGING AND DERIGGING ENGINE COWLING.....	2
PRE-FLIGHT INSPECTIONS.....	3
CHECKLISTS.....	7

INTRODUCTION

Section 4 contains checklists and the procedures for the conduct of normal operation.

RIGGING AND DERIGGING ENGINE COWLING

UPPER COWLING:

- I. Parking brake: *ON*
- II. Fuel selector valve: *OFF*
- III. Magnetos: *OFF*
- IV. Generator & Master switches: *OFF*
- V. Unlatch all four butterfly Cam-locks mounted on the cowling by rotating them 90° counterclockwise while slightly pushing inwards.
- VI. Remove engine cowling paying attention to propeller shaft passing through nose.
- VII. To assemble: rest cowling horizontal insuring proper fitting of nose base reference pins.
- VIII. Secure latches by applying light pressure, check for proper assembly and fasten Cam-locks.

WARNING

Butterfly Cam-locks are locked when tabs are horizontal and open when tabs are vertical. Verify tab is below latch upon closing.

LOWER COWLING

- I. After disassembling upper cowling, move the propeller to a horizontal position.
- II. Using a standard screwdriver, press and rotate 90° the two Cam-locks positioned on lower cowling by the firewall.
- III. Disconnect the ram-air duct from the NACA intake. Pull out the first hinge pin positioned on the side of the firewall, then, while holding cowling, pull out second hinge pin; remove cowling with downward motion.
- IV. For installation follow reverse procedure.

PRE-FLIGHT INSPECTIONS

Before each flight, it is necessary to carry out a complete inspection of the aircraft starting with an external inspection followed by an internal inspection as below detailed.

CABIN INSPECTION

- A Flight Manual: *check that a copy is on board*
- B Weight and balance: *check if within limits*
- C Safety belts: *flight controls free from safety belts*
- D Magnetos: *OFF*
- E Master switch: *ON and check the operation of the acoustic stall warning*
- F Master switch: *OFF*
- G Baggage: *check for a proper stowage and fastening with the retaining net*

EXTERNAL INSPECTION

To carry out the external inspection it will be necessary to follow the checklist below with the station order outlined in fig. 4-1.

WARNING

Visual inspection is defined as follows: check for defects, cracks, detachments, excessive play, unsafe or improper installation as well as for general condition. For control surfaces, visual inspection also involves additional check for freedom of movement and security.

- A Left fuel filler cap: check visually for desired fuel level. Drain the left fuel tank by drainage valve using a cup to collect fuel. Check for water or other contaminants.

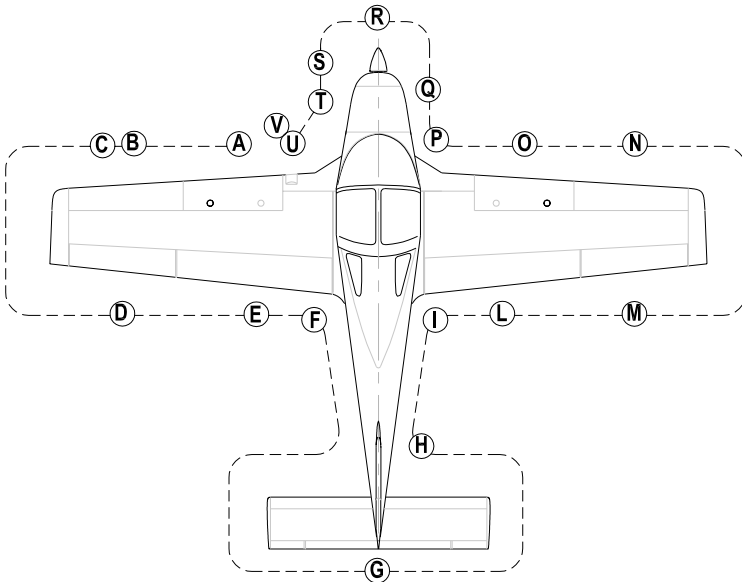

FIG. 4-1

WARNING

Fuel level indicated by the fuel quantity indicators (on the instrument panel) is only indicative. For flight safety, pilot should verify actual fuel quantity embarked before takeoff.

- B Remove protection cap and check the Pitot tube and the static ports mounted on left wing are unobstructed, do not blow inside vents, place protection cap inside the aircraft.
- C Left side leading edge and wing skin: visual inspection
- D Left aileron: visual inspection; Left tank vent: check for obstructions.
- E Left flap and hinges: visual inspection
- F Left main landing gear; check inflation 23 psi (1.6 bar), tire condition, alignment, fuselage skin condition.
- G Horizontal tail and tab: visual inspection.
- H Vertical tail and rudder: visual inspection.
- I Right main landing gear; check inflation 23 psi (1.6 bar), tire condition, alignment, fuselage skin condition.
- L Right flap and hinges: visual inspection.
- M Right aileron: visual inspection; Right side tank vent: check for obstructions.
- N Right leading edge and wing skin: visual inspection.
- O Right the side fuel filler cap for desired fuel level and secure. Drain the right fuel tank by the drainage valve using a cup to collect fuel. Check for water or other contaminants.
- P Set the fuel selector valve to OFF. Drain circuit using a cup to collect fuel by opening the specific drainage valve (part of the gascolator). Check for water or other contaminants (drainage operation must be carried out with the aircraft parked on a level surface).
- Q Nose wheel strut and tire: check inflation 15 psi (1.0 bar), tire condition and condition of rubber shock absorber discs.

- R Propeller and spinner condition: check for nicks and security.
- S Open engine cowling and perform the following checklist:
- I. Check no foreign objects are present.
 - II. Check the cooling circuit for losses, check coolant level into the expansion tank, insure radiator honeycomb is unobstructed.
 - III. Check lubrication circuit for losses, check oil reservoir level, and insure radiator honeycomb is unobstructed.
 - IV. Inspect fuel circuit for losses.
 - V. Check integrity of silent-block suspensions.
 - VI. Check connection and integrity of air intake system, visually inspect that ram air intake is unobstructed.
 - VII. Check that all parts are secured or safetied.
- T Close engine cowling.
- U Visual inspection of the Landing Light.
- V Remove tow bar and chocks.

NOTE

Avoid blowing inside Pitot-tube and inside airspeed indicator system's static vents as this may damage instruments.

CHECKLISTS

BEFORE STARTING ENGINE (after preflight inspection)

- I. Flight controls: *operate until their stop checking for movement smoothness*
- II. Parking brake: *engage*
- III. Throttle: *adjust friction*
- IV. Generator switch: *ON, generator light ON, check the ammeter.*
- V. Electric fuel pump: *ON, (check for audible pump noise and fuel pressure)*
- VI. Electric fuel pump: *OFF*
- VII. Avionic Master switch (if installed): *ON, instruments check, then set in OFF position*
- VIII. Flap control: *operate flap throughout their extreme positions*
- IX. Trim control: *operate from both left and right controls the trim between its extreme positions checking the trim position indicator*
- X. Nav. light & Strobe light: *ON*
- XI. Landing light: *ON, check*
- XII. Landing light: *OFF*
- XIII. Fuel quantity: *compare the fuel levels read by the fuel quantity indicators with the quantity present into the tanks (see Pre-flight inspection – External inspection)*
- XIV. Flight planning, fuel consumption, refuelling.
- XV. Seat position and safety belts adjustment

NOTE

In the absence of the passenger: fasten seat belts around the free seat so as to prevent interference with the operation of the aeroplane and with rapid egress in an emergency.

- XVI. Canopy: *Closed and locked*

CAUTION

Master Avionic switch (if installed) must be set OFF during the engine's start-up to prevent avionic equipments damages.

STARTING ENGINE

- I. Circuit Breakers: *check IN*
- II. Generator & Master switches: *ON*
- III. Fuel selector valve: *LEFT or RIGHT*
- IV. Electric fuel pump: *ON (check for audible pump noise and fuel pressure)*
- V. Engine throttle: *idle*
- VI. Choke: *as needed*
- VII. Propeller area: *CLEAR*
- VIII. Strobe light: *ON*

WARNING

Check to insure no person or object is present in the area close to propeller.

- IX. Magnetos: *BOTH*
- X. Magnetos: *START*
- XI. Check oil pressure rise within 10 sec. (maximum cold value 7 bar)
- XII. Check engine instruments
- XIII. Choke: *OFF*
- XIV. Propeller rpm: *1000-1100 rpm*
- XV. Electric fuel pump: *OFF*
- XVI. Check fuel pressure
- XVII. Electric fuel pump: *ON*

BEFORE TAXIING

- I. Radio and Avionics: *ON*
- II. Altimeter: *set*
- III. Direction indicator: *set in accordance with the magnetic compass*
- IV. Parking brake: *OFF and taxi*

TAXIING

- I. Brakes: *check*
- II. Flight instruments: *check*

PRIOR TO TAKE-OFF

- I. Parking brake: *ON*
- II. Check engine instruments:
 - Oil temperature: 50-110 °
 - Cylinder heads temperature: max 135 °
 - Oil pressure: 2-5 bar (*above 1400 rpm*); 0.8 bar (*below 1400 rpm*)
 - Fuel pressure: 2.2 – 5.8 psi (*0.15-0.40 bar*)
- III. Generator light: *OFF (check)*
- IV. Propeller's rpm: *1560 and test magnetos (speed drop with only one ignition circuit must not exceed 130 prop's rpm; maximum difference of speed by use of either circuits LEFT or RIGHT is 50 rpm).*
- V. Check fuel quantity indicators.
- VI. Flaps: *T/O (15°)*
- VII. Stick free and trim set at *zero*
- VIII. Seat belts fastened and canopy closed and locked

TAKEOFF AND CLIMB

- I. Call TWR for takeoff
- II. Check for clear final and wind on runway
- III. Parking brake: *OFF*
- IV. Carburetor heat: *OFF*
- V. Taxi to line-up
- VI. Check magnetic compass and direction indicator
- VII. Full throttle (approx. 2100 ± 100 rpm)
- VIII. Engine instruments: *check*
- IX. Rotation speed $V_r = 45$ KIAS
- X. Rotation and takeoff
- XI. Slight braking to stop wheel spinning
- XII. Flaps: *retraction (at 300ft AGL)*
- XIII. Establish climb rate ($V_y \cong 65$ KIAS)
- XIV. Trim adjustment
- XV. Electric fuel pump: *OFF*

CRUISE

- I. Reach cruising altitude
- II. Set power and engine rpm's for cruise.
- III. Check engine instruments
 - Oil temperature: $90^\circ - 110^\circ$ °C.
 - Temperature cylinder heads: $90^\circ \div 135^\circ$ °C
 - Oil pressure: 2 - 5 bar.
 - Fuel pressure: 2.2 – 5.8 psi (*0.15 – 0.40 bar*)
- IV. Carburettor heat as needed, see paragraph on carb. heat in Section 3.

NOTE

Compensate unpredicted asymmetrical fuel consumption between left and right fuel tanks operating the fuel selector valve. Switch on the electric fuel pump prior to swap the fuel feeding from one tank to another

BEFORE LANDING

- I. Electric fuel pump: *ON*
- II. On downwind leg: *speed 67 KIAS; Flaps: T/O (15°)*
- III. On final leg: *speed 62 KIAS; Flaps: Land (40°)*
- IV. Establish descent
- V. Optimal touchdown speed: *50 KIAS*

BALKED LANDING

- I. Full throttle
- II. Speed: *60 KIAS*
- III. Electric fuel pump: *ON (check)*
- IV. Flaps position: *TO*

AFTER LANDING

- I. Taxiing at an appropriate speed
- II. Flaps: *UP*
- III. Complete stop at parking
- IV. Parking brake: *engage*

ENGINE SHUT DOWN

- I. Keep engine running at 1200 rpm for about one minute in order to reduce latent heat.
- II. Electric fuel pump: *OFF*
- III. Turn off all electrical utilities (with the exception of the Strobe Light)
- IV. Magnetos: *OFF*
- V. Strobe light: *OFF*
- VI. Master & Generator switches: *OFF*
- VII. Fuel selector valve: *OFF*
- VIII. Parking brake: *engaged (check)*

POSTFLIGHT CHECK

- I. Insert hood over pitot tube on left wing
- II. Close canopy.

SECTION 5

PERFORMANCES

TABLE OF CONTENTS

INTRODUCTION.....	2
USE OF PERFORMANCE CHARTS.....	2
AIRSPED INDICATOR SYSTEM CALIBRATION.....	3
STALL SPEED (<i>APPROVED DATA</i>).....	5
CROSSWIND.....	6
TAKEOFF PERFORMANCES (<i>APPROVED DATA</i>).....	7
CLIMB PERFORMANCES.....	9
CRUISE.....	10
BALKED LANDING.....	11
LANDING DISTANCE (<i>APPROVED DATA</i>).....	12
CONSEQUENCES FROM RAIN AND INSECT.....	13
NOISE DATA.....	14

INTRODUCTION

This section provides all necessary data for accurate and comprehensive planning of flight activity from takeoff to landing.

Data reported in graphs and/or in tables were determined using:

- “Flight Test Data” under condition prescribed by EASA CS-VLA
- aircraft and engine in good condition
- average piloting techniques

Each graph or table was determined according to ICAO Standard Atmosphere (ISA - m.s.l.); evaluations of the impact on performance was carried out by theoretical means for:

- airspeed
- external temperature
- altitude
- weight
- type and condition of runway

Sections approved by EASA are marked with: “*Approved data*”.

USE OF PERFORMANCE CHARTS

Performance data is presented in tabular or graphical form to illustrate the effect of different variables such as altitude, temperature and weight. Given information is sufficient to plan journey with required precision and safety. Additional information is provided for each table or graph.

AIRSPED INDICATOR SYSTEM CALIBRATION

(Approved data)

Graph shows calibrated airspeed V_{CAS} as a function of indicated airspeed V_{IAS} .

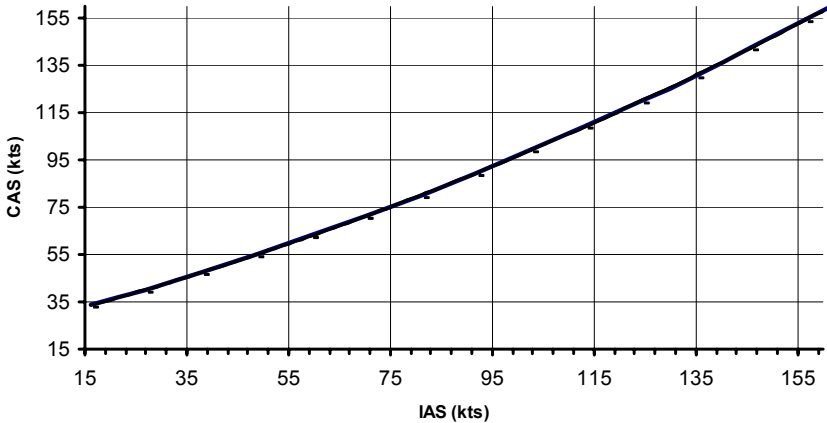

Fig. 5-1. CALIBRATED VS. INDICATED AIRSPEED -

⇒ Example:

Given
 $V_{IAS} = 115$ kts

Find
 $V_{CAS} = 111$ kts

NOTE

Indicated airspeed assumes 0 as an instrument error

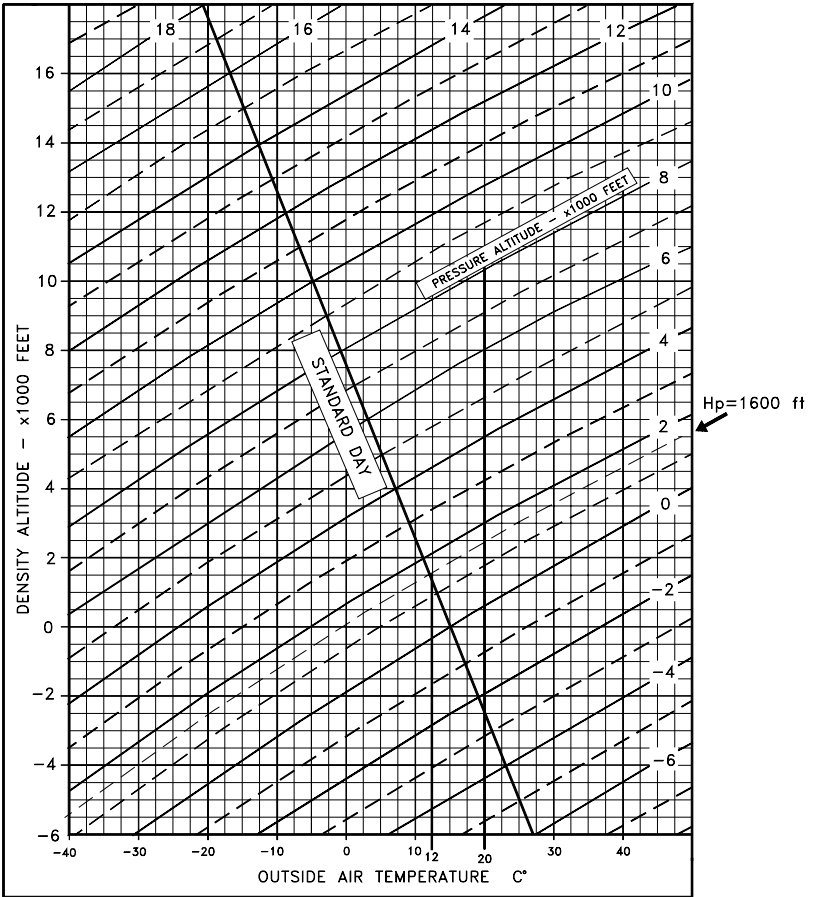

Fig.5-2. ICAO CHART

⇒ Example:

Given
Temperature = 20°C
Pressure Altitude = 1600 ft

Find
 $T_s = 12^\circ$

STALL SPEED *(Approved data)*

CONDITIONS: - Weight 580 kg
 - Throttle: idle
 - No ground effect

NOTE

Altitude loss during conventional stall recovery as demonstrated during test flights is approximately 100ft with banking under 30°.

LATERAL BANK									
		0 °		30 °		45 °		60 °	
FLAP	KIAS	KCAS	KIAS	KCAS	KIAS	KCAS	KIAS	KCAS	
0°	40	49	43	51	48	54	57	61	
15°	28	41	30	42	33	44	40	49	
40°	26	40	28	41	31	43	37	47	

CROSSWIND

Maximum demonstrated crosswind velocity is 22 Kts

⇒ Example:

Given
Wind direction = 30°
Wind velocity = 20 Kts

Find
Headwind = 17.5 Kts
Crosswind = 10 Kts

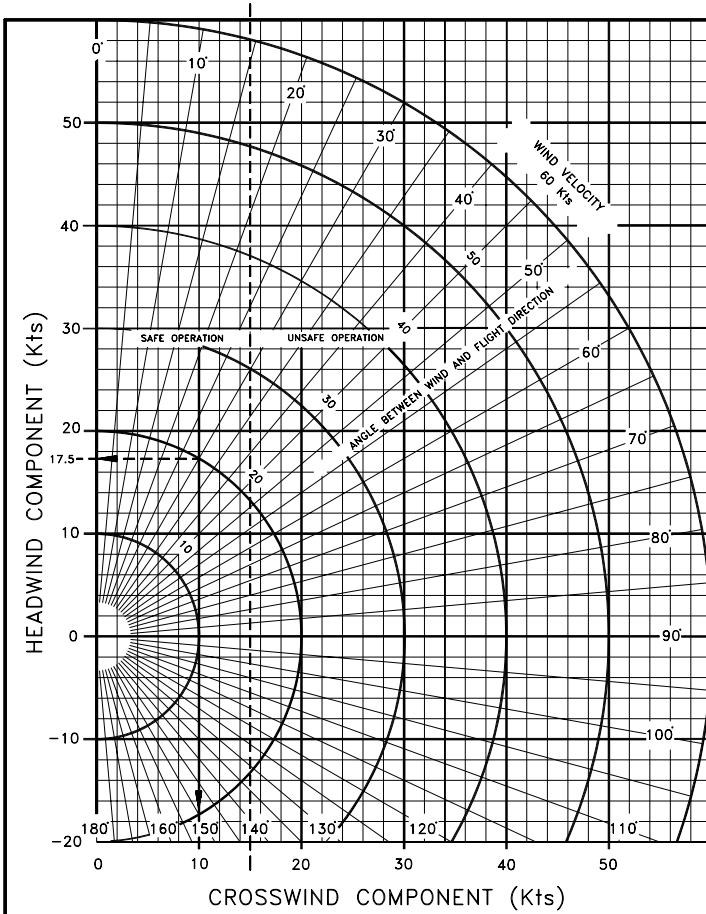

Fig.5-3.CROSSWIND CHART

1st revision, August 3rd 2005

TAKEOFF PERFORMANCES *(Approved data)*

TAKEOFF DISTANCE

CONDITIONS:

- Flaps: 15°
- Engine throttle: full throttle *(see Sect.4)*
- $V_R = 45$ KIAS
- $V_{obs} = 45$ KIAS
- Runway: dry, compact, grass
- Slope: 0°; Wind: zero
- $V_{LO} = 35$ KIAS
- $R/C \geq 200$ ft/min

⇒ *Example:*

Given
O.A.T. = 15°C
Pressure altitude = 2900 ft
Weight = 480 Kg

Find
TOD = 280m
TOR = 132m

Fig. 5-4. TAKEOFF PERFORMANCES

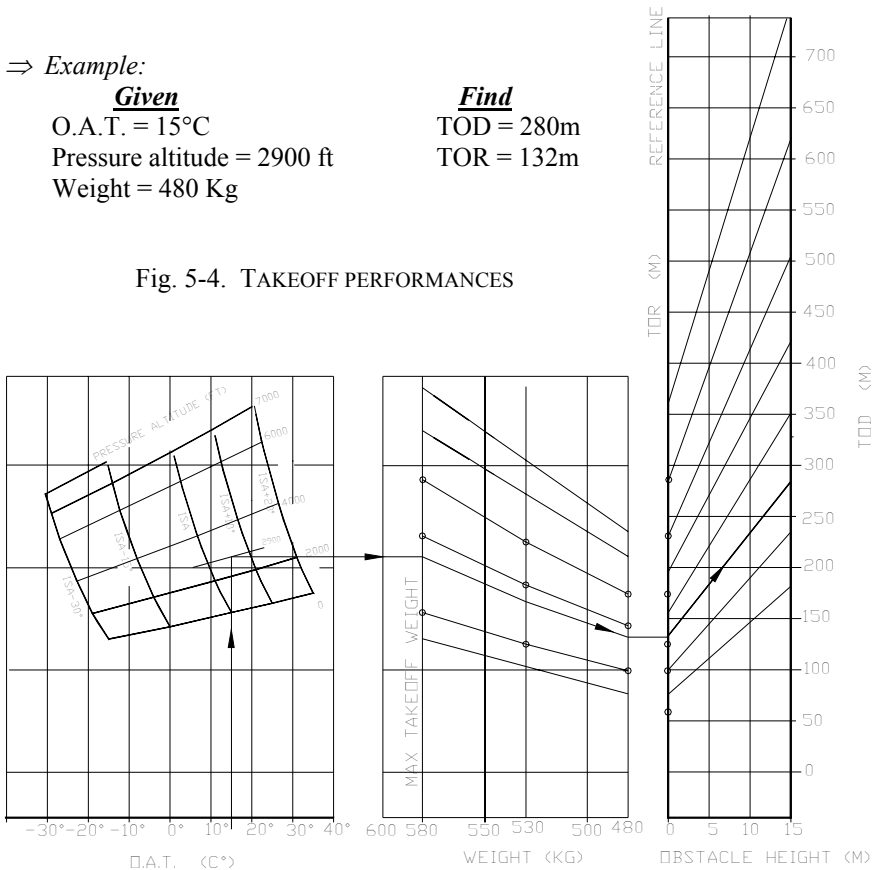

NOTE

1. *Decrease distances by 10% for each 10Kts of ahead wind.
Increase distances by 20% for each 10 Kts of tailwind.*
2. *For dry and paved runway operation decrease round run
by 6%.*

CLIMB RATE IN TAKEOFF CONFIGURATION (*Approved data*)**CONDITIONS:**

- Flaps: 15°
- Engine: full throttle.
- V_{obs} : 45 KIAS

Climb rate at maximum takeoff weight (580kg) in demonstrated ISA s.l. conditions is 850 ft/min.

CLIMB PERFORMANCES

CLIMB RATE IN CLEAN CONFIGURATION

CONDITIONS:

- Flap: 0°
- Engine: Full throttle
- $V_Y = 65$ KIAS
- R/C residual: 100 ft/min.

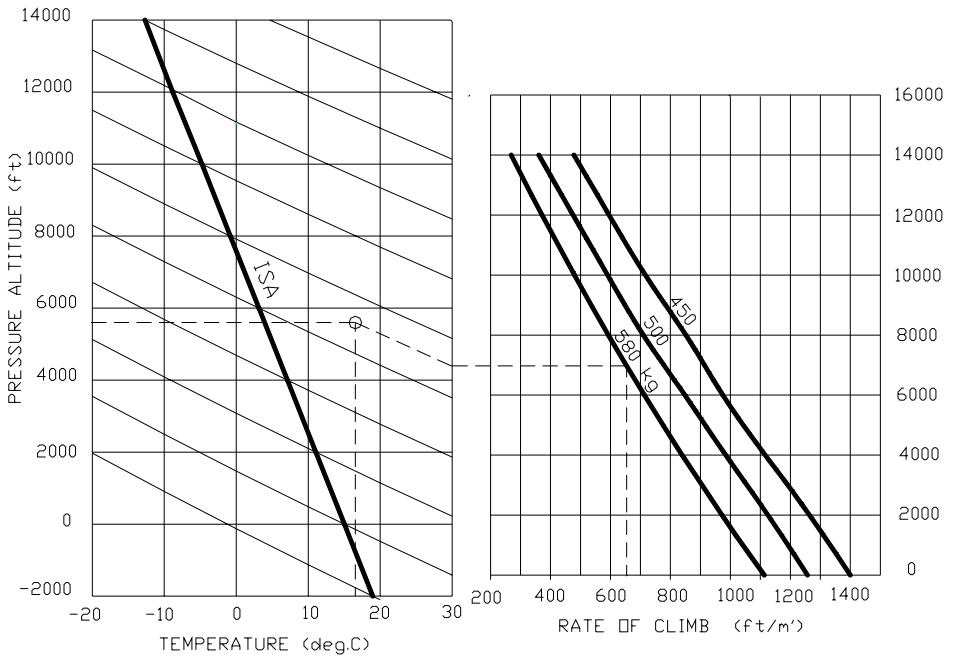

Fig. 5-5 CLIMB

⇒ *Example:*

Given

- O.A.T. = 17°C
- Pressure altitude = 5600 ft
- Weight = 580 Kg

Find

Rate of climb = 654 ft/min

CRUISE

CONDITIONS:

- ISA
- Wind: zero
- MTOW = 580 kg

TAS (KTS)

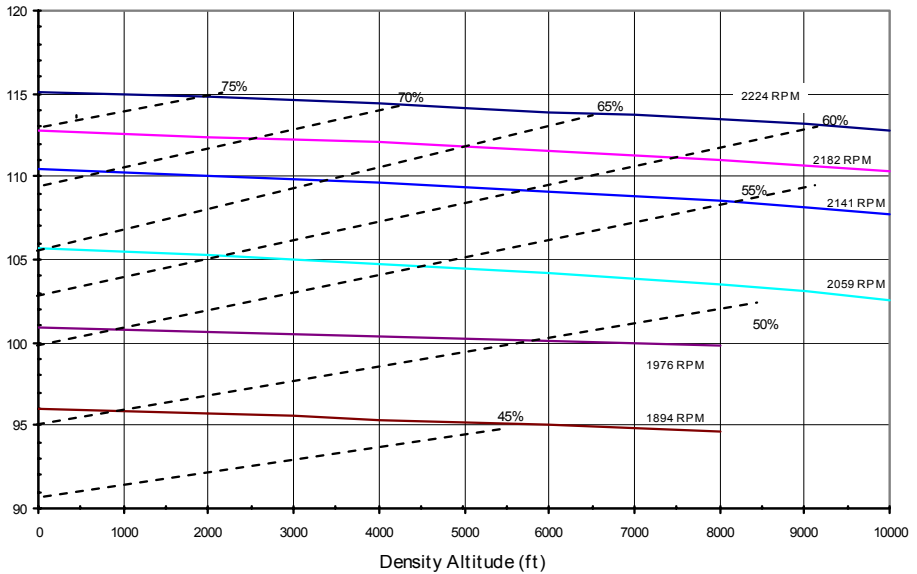

Fig. 5-6 CRUISE

BALKED LANDING

RATE OF CLIMB: BALKED LANDING

CONDITIONS:

- Maximum weight = 580 kg
- Engine: full throttle
- Flaps: LAND (40°)
- V_{Obs} = 48 KIAS

NOTE

During balked landing manoeuvre, flaps should be retracted immediately after applying full power.

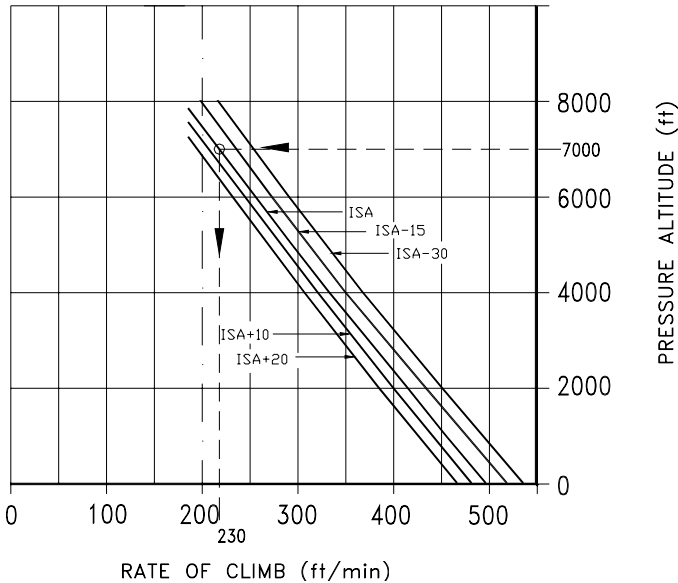

Fig.5-7 BALKED LANDING

⇒ *Example:*

Given

Pressure altitude = 7000 ft

Conditions: ISA

Find

Rate of climb = 230 ft/min

LANDING DISTANCE (*Approved data*)

LANDING DISTANCE AND GROUND ROLL

CONDITIONS:

- Weight: 480 kg; Flap: 40°
- Runway: dry, compact, grass
- Engine: idle
- Slope: 0°; Wind: zero

Distance over the obstacle of 15 m

OAT: ISA -20°C

Hp (ft)	Total Distance (m)	Ground Run (m)
0	235	88
2000	241	94
4000	248	99
6000	256	105

OAT: ISA -10°C

Hp (ft)	Total Distance (m)	Ground Run (m)
0	239	92
2000	246	97
4000	253	103
6000	261	109

OAT: ISA +0°C

Hp (ft)	Total Distance (m)	Ground Run (m)
0	243	95
2000	250	101
4000	258	107
6000	266	113

OAT: ISA +10°C

Hp (ft)	Total Distance (m)	Ground Run (m)
0	247	98
2000	255	104
4000	263	111
6000	271	118

OAT: ISA +20°C

Hp (ft)	Total Distance (m)	Ground Run (m)
0	251	101
2000	259	108
4000	268	114
6000	277	122

NOTE

1. *Decrease distances by 10% for each 10 Kts of headwind. Increase distances by 20 % for each 10 Kts of tailwind;*
2. *For dry and paved runway operation increase ground run by 10%;*
3. *If it becomes necessary to land without flap extension (flap malfunction), increase approach speed by 10 Kts, increase by 40% distance pertaining to flap setting at 40° and increase V_{obs} to 56 KIAS;*
4. *V_{obs} (speed over obstacle) is 48 KIAS;*

CONSEQUENCES FROM RAIN AND INSECT

Flight test have demonstrated that neither rain nor insect impact build-up on leading edge have caused substantial variations to aircraft's flight qualities. Such variations do not exceed: 5 kts for stalls, 100 ft/min for climb rates and 50m for takeoff runs.

NOISE DATA

Noise level was determined according to EASA CS-36 1st edition dated 17th October 2003, with reference to ICAO/Annex 16 3rd edition dated 1993, Vol. I° chapter 10, and resulted equal to **62.36** db.

SECTION 6

WEIGHT & BALANCE

TABLE OF CONTENTS

INTRODUCTION.....	2
AIRCRAFT WEIGHING PROCEDURES.....	2
WEIGHT AND BALANCE.....	6
LOADING.....	9
EQUIPMENT LIST	9

INTRODUCTION

This section describes the procedure for establishing the basic empty weight and moment of the aircraft. Loading procedure information is also provided.

AIRCRAFT WEIGHING PROCEDURES

PREPARATION

- a. Carry out weighing procedure inside closed hangar
- b. Remove from cabin any objects left unintentionally
- c. Insure on board presence of the Flight Manual
- d. Align nose wheel
- e. Drain fuel via the specific drain valve.
- f. Oil, hydraulic fluid and coolant to operating levels
- g. Move sliding seats to most forward position
- h. Raise flaps to fully retracted position (0°)
- i. Place control surfaces in neutral position
- j. Place scales (min. capacity 200 kg) under each wheel

LEVELLING

- a. Level the aircraft.
Reference for levelling: remove a seat and then place a level between the two seat's fwd and aft supporting trusses.
- b. Center bubble on level by deflating nose tire

WEIGHING

- a. Record weight shown on each scale
- b. Repeat weighing procedure three times
- c. Calculate empty weight

DETERMINATION OF C.G. LOCATION (SEE FIG. 6-1)

- a. Drop a plumb bob tangent to the leading edge (at 15mm inboard respect the rib#7 riveting line) and trace reference mark on the floor.
- b. Repeat operation for other wing.
- c. Stretch a taught line between the two marks
- d. Measure the distance between the reference line and main wheel axis
- e. Using recorded data it is possible to determine the aircraft's C.G. location and moment (see following table)

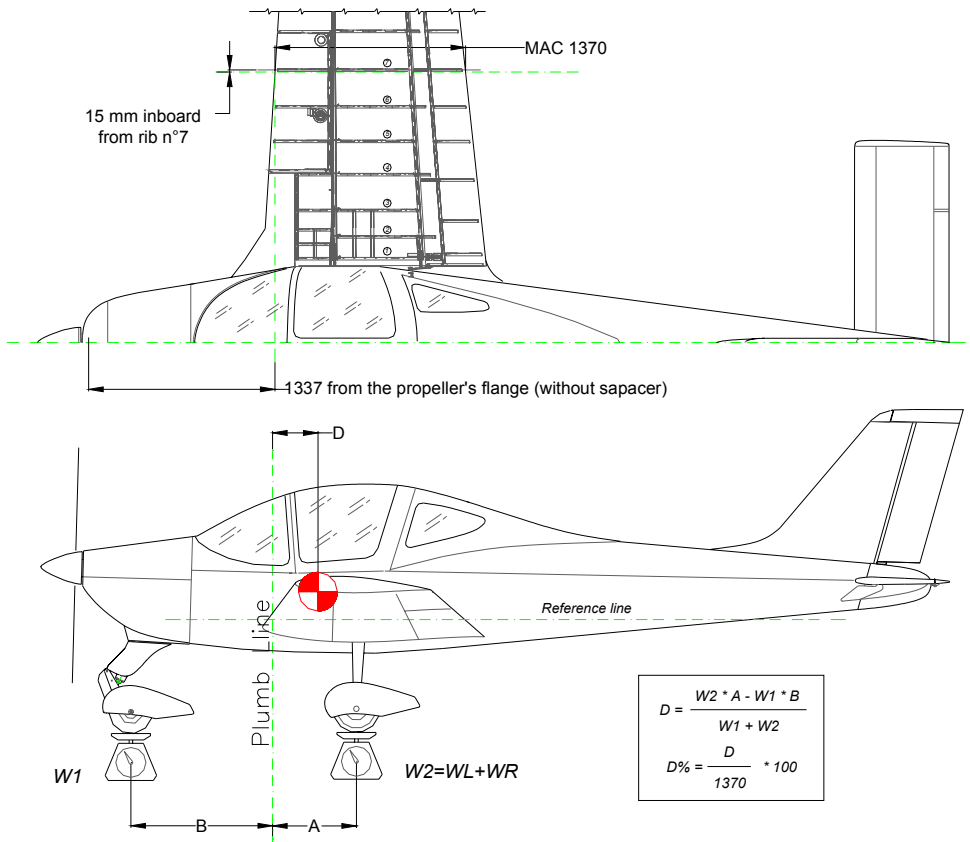
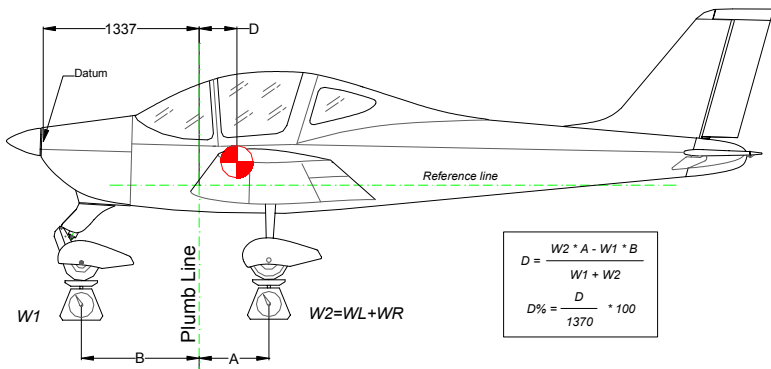

Fig.6-1

WEIGHING REPORT

Model **P2002-JF** S/N: _____ Weighing n° _____ Date: _____

Datum: Propeller support flange without spacer.



	Kg		meters
Nose wheel weight	$W_1 =$	Plumb bob distance ⁽¹⁾ LH wheel	$A_L =$
LH wheel weight	$W_L =$	Plumb bob distance ⁽¹⁾ RH wheel	$A_R =$
RH wheel weight	$W_R =$	Average distance $(A_L + A_R)/2$	$A =$
$W_2 = W_L + W_R =$		Bob distance from nose wheel ⁽¹⁾	$B =$

Empty weight $W_e = W_1 + W_2 =$

$$D = \frac{W_2 \cdot A - W_1 \cdot B}{W_e} = \quad m$$

$$D\% = \frac{D}{1.370} \cdot 100 =$$

Empty weight moment: $M = [(D+1.337) \cdot W_e] = \quad Kg \cdot m$

Maximum takeoff weight	$W_T =$	580 Kg.
Empty weight	$W_e =$	
Maximum payload $W_T - W_e$	$W_u =$	

(1) To determine the Mean Aerodynamic Chord (MAC) and the plumb line see FIG. 6-1.

WEIGHING REPORT

Model **P2002-JF** S/N: _____ Weighing n° _____ Date: _____

Datum: Propeller support flange without spacer.

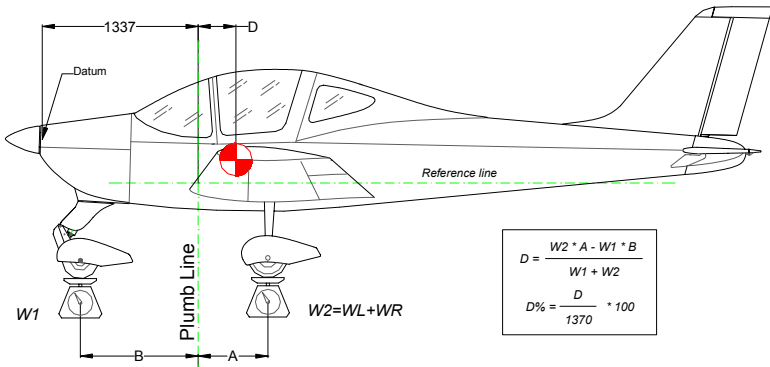

	Kg
Nose wheel weight	$W_1 =$
LH wheel weight	$W_L =$
RH wheel weight	$W_R =$
$W_2 = W_L + W_R =$	

	meters
Plumb bob distance ⁽¹⁾ LH wheel	$A_L =$
Plumb bob distance ⁽¹⁾ RH wheel	$A_R =$
Average distance $(A_L + A_R)/2$	$A =$
Bob distance from nose wheel ⁽¹⁾	$B =$

Empty weight $W_e = W_1 + W_2 =$

$D = \frac{W_2 \cdot A - W_1 \cdot B}{W_e} =$	m	$D\% = \frac{D}{1.370} \cdot 100 =$
---	-----	-------------------------------------

Empty weight moment: $M = [(D+1.337) \cdot W_e] =$ $Kg \cdot m$

Maximum takeoff weight	$W_T =$ 580 Kg.
Empty weight	$W_e =$
Maximum payload $W_T - W_e$	$W_u =$

(1) To determine the Mean Aerodynamic Chord (MAC) and the plumb line see FIG. 6-1.

WEIGHT AND BALANCE

To determine the aircraft's CG location and to verify that the CG lies within the predetermined CG travel range, it would be helpful to use the chart in the following page. Chart reports CG location as a function of the empty weight moment with respect to the datum as yielded by weighing report.

USE OF “WEIGHT & BALANCE” CHART (page 6-7)

In order to use the graph it is necessary to know the value of the moment arm (empty weight conditions) with respect to the datum. Once this value is found on the abscissa, a parallel to the oblique lines is drawn until it intersects the ordinate relative to the weight of pilot and passenger. From this point, a new line is drawn horizontally up to the graph limit-value of 200 kg and, from here, a parallel to the oblique lines is drawn until it intersects with the abscissa relative to fuel weight carried on board. A horizontal line is then drawn through this point up to the graph limit-value of 100 liters and a new parallel to the oblique lines is drawn until abscissa is intercepted relative to baggage loaded on board behind the seats. Another horizontal line is drawn and it is thus possible to verify that the intersection of this segment with the vertical abscissa relative to the aircraft's takeoff total weight falls within the shaded area which represents the admissible CG range as a function of total weight.

Other charts show the CG travel as a function of aircraft weight, distances in meters of pilots and baggage from datum (propeller support flange) is also provided.

EXAMPLE (see page 6-7)

Empty weight moment = 581 $kg \cdot m$

Pilot and passenger = 160 kg

Fuel = 50 L

Baggage = 15 kg

Takeoff weight = 548 kg

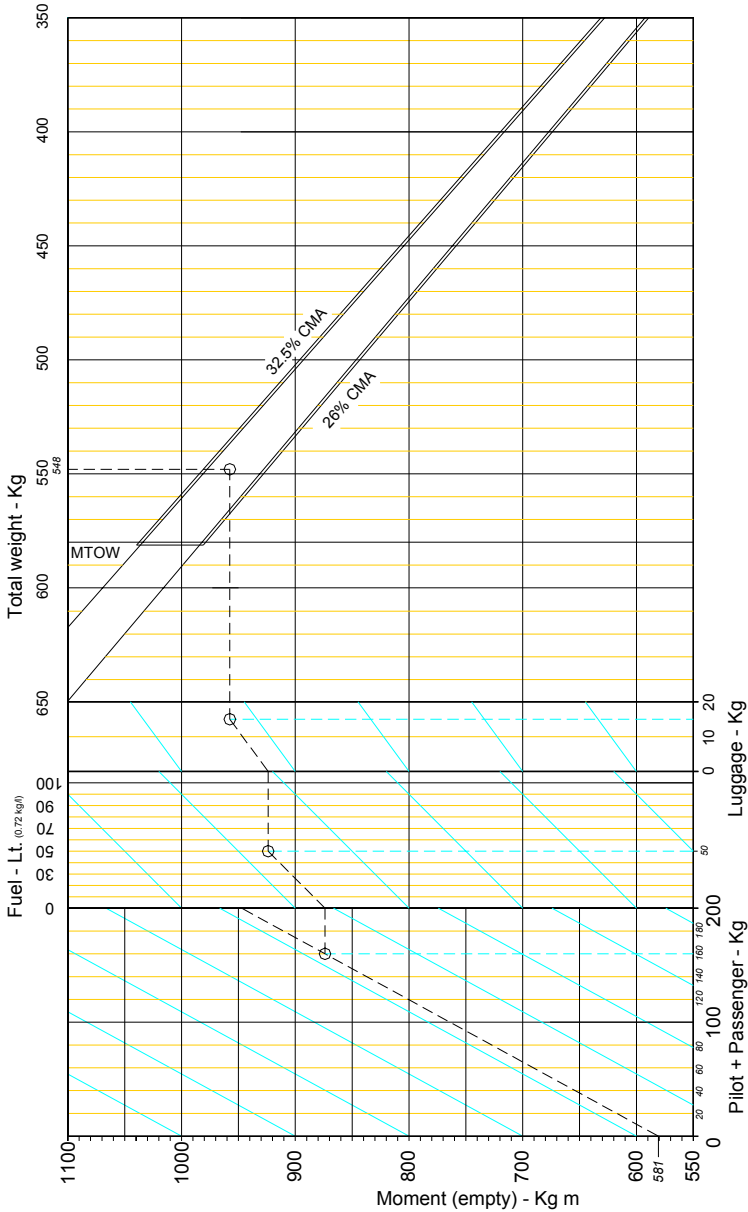

FIG. 6-2 Weight & balance chart

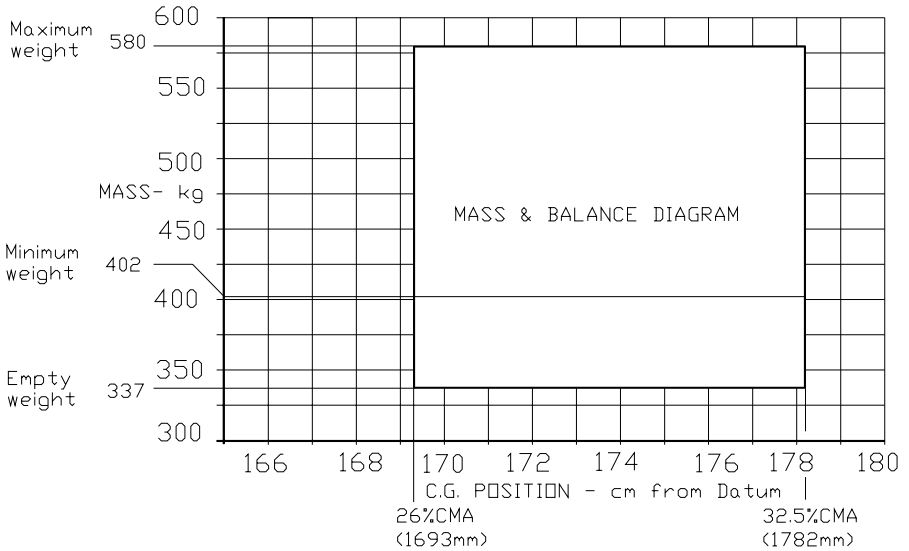

Fig 6-3 C.G. RANGE CHART

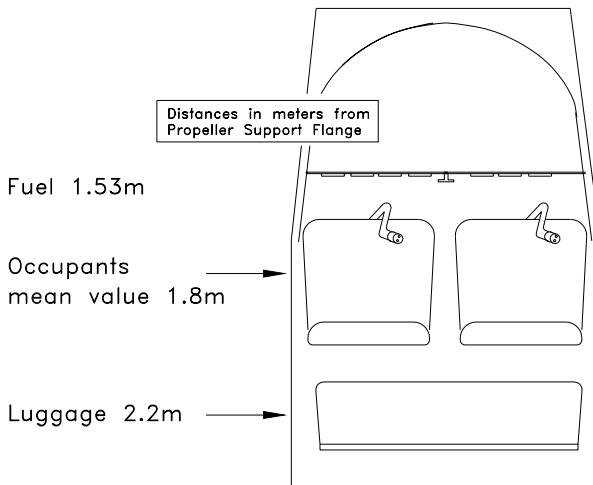

Fig 6-4 LOAD POSITION WITH RESPECT TO DATUM

LOADING

Luggage compartment is designed for a maximum load of 20 kg. Luggage size shall prevent excessive loading of utility shelf (maximum pressure 12.5 kg/dm²). Maximum Luggage size is: 80x45x32 cm. Luggage must be secured using a tie-down net to prevent any luggage movement during maneuvers.

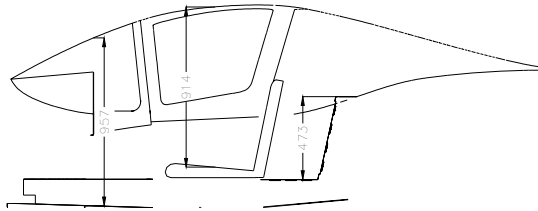

Fig 6-5 CABIN DIMENSIONS

EQUIPMENT LIST

The following is a comprehensive list of all TECNAM supplied equipment for the P2002-JF. The list consists of the following groups:

- A - *Engine and accessories*
- B - *Landing gear*
- C - *Electrical system*
- D - *Instruments*
- E - *Avionics*

the following information describes each listing:

- Part-number to uniquely identify the item type.
- Item description
- Serial number
- Weight in kilograms
- Distance in meters from datum

NOTE

Items marked with an asterisk () are part of basic installation.
Equipment marked with X in the Inst. column are those actually
installed on board relative to aircraft S/N.*

EQUIPMENT LIST		A/C s/n		DATE:	
RIF.	DESCRIPTION & P/N	S/N	INST	WEIGHT kg	DATUM m
<i>ENGINE & ACCESSORIES</i>					
A1	Engine Rotax 912S2 - p/n 309.120.133		*	61.0	0.32
A2	Prop. HOFFMANN p/n HO17GHM A 174 177C		*	6.0	-0.13
A3	Exhaust and manifolds - p/n 973670	--	*	4.50	0.55
A4	Heat exchanger - p/n 92-11-830	--	*	2.00	0.55
A5	Oil Reservoir (full) - p/n 956.137	--	*	4.00	0.64
A6	Oil radiator - p/n 886 025	--	*	0.40	0.07
A7	Liquid coolant radiator. - p/n 995.697	--	*	0.90	0.33
A8	Air filter K&N- p/n 33-2544	--	*	0.40	0.60
A9	Vacuum Pump- RA215CC Rapco or AA3215C Temptest		*	2.00	0.25
A10	Vacuum valve 2H3-6 p/n 10AK		*	0.10	0.71
A11	Fuel pump p/n 21-11-342-000	--	*	0.10	0.71
<i>LANDING GEAR AND ACCESSORIES</i>					
B1	Main gear spring-leafs - p/n 92-8-300-1	--	*	5.700	1.94
B2	Main gear wheel rims. - Cleveland 40-78B	--	*	2.050	1.94
B3	Main gear tires.-Air Trac 5.00-5 AA1D4	--	*	2.580	1.94
B4	Disk brakes - Cleveland 30-9	--	*	0.800	1.94
B5	Nose gear wheel rim - p/n 92-8-880-1	--	*	1.300	0.310
B6	Nose gear tire - Sava 4.00-6	--	*	1.200	0.460
B7	Nose gear fairing p/n 92-8-410-1/2	--		1.500	0.460
B8	Main gear fairing p/n 92-8-420-1/2	--		1.500	1.930
B9	Nose gear shock p/n 92-8-200-000	--	*	1.450	0.465

EQUIPMENT LIST		A/C S/N		DATE:	
REF.	DESCRIPTION & P/N	S/N	INST	WEIGHT kg	DATUM m
	<i>ELECTRICAL SYSTEM</i>				
C1	Battery FIAMM 6H4P 12V 18Ah	--	*	6.00	2.59
C2	Regulator, rectifier - p/n 945.345	--	*	0.20	0.82
C3	Battery relay - p/n 111-226-5	--	*	0.30	2.59
C4	Flaps actuator control - CALA33X150/c21A	--	*	2.20	2.30
C5	Trim actuator control MAC6A	--	*	0.40	5.73
C6	Overvoltage sensor OS75-14 or ZEFTRONICS V1510A		*	0.30	0.80
C7	Strobe light - AS A555A-V-14V	--		0.15	5.89
C8	Navigation lights - AS W1285	--		0.15	1.75
C9	Stall warning - AS 164R	--	*	0.10	1.36
C10	Landing light - AS GE 4509	--		0.50	1.38
	<i>Instruments</i>				
D1	Altimeter United Instruments p/n 5934PM-3 or LUN 1128.10B4 -TSO C10b		*	0.39	1.35
D2	Anemometro - UMA T6-311-161 - TSO C2b		*	0.30	1.35
D3	Compass - Airpath C2300- TSO		*	0.29	1.35
D4	Clock - Quartz Chronometer LC2 AT420100		*	0.15	1.35
D5	Vertical speed indicator - VSI 2FM-3		*	0.35	1.35
D6	Turn and Bank Indicator - FALCON GAUGER TC02E-3-1		*	0.56	1.35
D7	Attitude Indicator - GH-02V-3		*	1.10	1.35
D8	Directional Gyro - FALCON GAUGER DG02V-3		*	1.10	1.35
D9	OAT Indicator - VDO 397035001G	--	*	0.05	1.35
D10	Oil & head temp.indicator VDO 641-011-7047/-7048	--	*	0.10	1.35
D11	Oil Temp.Ind. - VDO 644-001-7030	--	*	0.10	1.35
D12	Trim Position Indicator -MAC S6A		*	0.05	1.35

EQUIPMENT LIST		A/C S/N		DATE:	
REF.	DESCRIPTION & P/N	S/N	INST	WEIGHT kg	DATUM m
D13	Vacuum Instr.Ind. Varga Enterprise 10-01100	--	*	0.10	1.35
D14	Prop. RPM Ind. Aircraft Mitchell. D1-112- 5041		*	1.10	1.35
D15	Fuel Quantity Ind. Road GmbH XID4000800	--	*	0.56	1.35
D16	Amperometer Ind. VDO 190-037-001G or Speed Com Instruments 0203		*	010	1.35
D17	Fuel Pressure Ind. Mitchell Aircraft Inst. 10-25-058		*	010	1.35
	AVIONICS AND OTHERS				
E1	Nav/CommTrans.-Bendix/King, KX155			2.24	1.35
E2	Nav Indicator - Bendix/King KI208			0.46	1.35
E3	Transponder - Bendix/King KT76A			1.36	1.35
E4	GPS/NAV Receiver and R/T COM GNS 430			2.31	1.35
E5	R/T VHF COMM ICOM IC-A200			1.20	1.35
E6	ELT ACK - Model E-01			1.10	2.74
E7	Transponder-Garmin GTX320			1.00	1.35
E7	Transponder-Garmin GTX327			1.00	1.35
E8	Audio panel -Garmin GMA 340			0.50	1.35
E9	Vor/Loc Indicator-Garmin GI106A			0.64	1.35
E10	Transponder Antenna-Bendix/King KA60			0.17	1.09
E11	Transponder Antenna Garmin GTX320/327			0.17	1.09
E12	Mic - Telex TRA 100			0.17	1.90
E13	GPS Antenna.Garmin GA56			0.27	1.08
E14	Comm Antenna Command Industries CI 291			0.34	3.30

EQUIPMENT LIST		A/C S/N		DATE:	
REF.	DESCRIPTION & P/N	S/N	INST	WEIGHT <i>kg</i>	DATUM <i>m</i>
E15	VOR/ILS Antenna. Command Industries CI 138C			0.26	5.80
E16	ELT Antenna Kit Model E-01			0.21	2.70
E17	Fire Extinguisher Enterprises Ltd BA51015-3			2.20	2.32
E18	First Aid Kit		*	0.28	2.30
E19	Altitude Encoder- Amery King Ak-30		*	0.25	1.00
E20	Emergency Hammer-Dmail 108126		*	0.35	2.30

INTENTIONALLY LEFT BLANK

SECTION 7

AIRCRAFT & SYSTEMS DESCRIPTION

TABLE OF CONTENTS

INTRODUCTION.....	2
AIRFRAME.....	2
FLIGHT CONTROLS.....	3
INSTRUMENT PANEL.....	4
SEATS AND SAFETY HARNESS.....	5
CANOPY.....	5
BAGGAGE COMPARTMENT.....	5
POWERPLANT.....	6
FUEL SYSTEM.....	6
ELECTRICAL SYSTEM.....	8
PITOT AND STATIC PRESSURE SYSTEMS.....	10
BRAKES.....	11

INTRODUCTION

This section provides description and operation of the aircraft and its systems.

AIRFRAME

WING

The wing is constructed of a central light alloy torque box; an aluminium leading edge with integrated fuel tank is attached to the front spar while flap and aileron are hinged to rear spar. Flaps and ailerons are constructed of a centre spar to which front and rear ribs are joined; wrap-around aluminium skin panels cover the structure.

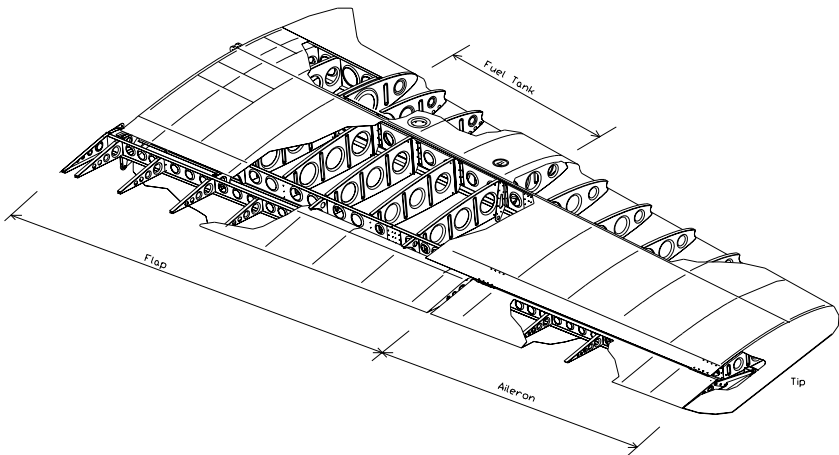

Fig. 7-1. RIGHT WING EXPLODED VIEW

FUSELAGE

The front part of the fuselage is made of a mixed structure: a truss structure with special steel members for cabin survival cell, and a light-alloy semi-monocoque structure for the cabin's bottom section. The aft part of the fuselage is constructed of an aluminium alloy semi-monocoque structure. The engine housing is isolated from the cabin by a firewall; the steel stringers engine mount is attached to the cabin's truss structure in four points.

EMPENNAGES

The vertical tail is entirely metal: the vertical fin is made up of a twin spar with stressed skin while the rudder consists of an aluminium torque box made of light alloy ribs and skin. The horizontal tail is an all-moving type (stabilator); its structure consists of an aluminium tubular spar connected to ribs and leading edge covered by an aluminium skin.

FLIGHT CONTROLS

Aircraft flight controls are operated through conventional stick and rudder pedals. Longitudinal control acts through a system of push-rods and is equipped with a trim tab. Aileron control is of mixed type with push-rods and cables; the cable control circuit is confined within the cabin and is connected to a pair of push-rods positioned in the wings that control ailerons differentially. Aileron trimming is carried out on ground through a small tab positioned on left aileron.

Flaps are extended via an electric servo actuator controlled by a switch on the instrument panel. Flaps act in continuous mode; the indicator displays the two positions relative to takeoff (15°) and landing (40°). A breaker positioned on the right side of the instrument panel protects the electric circuit.

Longitudinal trim is performed by a small tab positioned on the stabilator and controlled via an electric servo by pushing Up/Down the push-button on the control stick, a shunt switch placed on the instrument panel enables control of either left or right stick.

INSTRUMENT PANEL

The conventional type instrument panel allows placement of a broad range of equipment. Instruments marked with an asterisk (*) are optional.

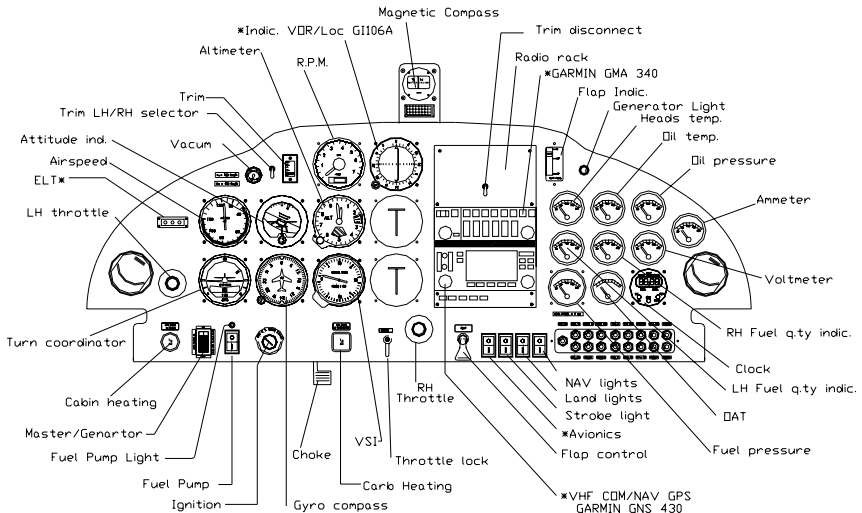

Fig. 7-2. INSTRUMENT PANEL

CARBURETTOR HEAT

Carburettor heat control knob is located just to the left of the centre throttle control; when the knob is pulled fully outward from the instrument panel, carbs receive maximum hot air. During normal operation, the knob is OFF.

CABIN HEAT

The cabin heat control knob is positioned on the lower left side of the instrument panel; when knob is pulled fully outward, cabin receives maximum hot air. Vents are located by the rudder pedals and above instrument panel. If necessary, outside fresh air can be circulated inside cabin by opening the vents on the dashboard.

THROTTLE FRICTION LOCK

It is possible to adjust the engine's throttle friction lock by appropriately tightening the friction lock knob located on the instrument panel near the center throttle control.

SEATS AND SAFETY HARNESS

Aircraft features four point fitting safety belts with waist and shoulder harnesses adjustable via sliding metal buckle.

Seats are built with light alloy tube structure and synthetic material cushioning. A lever located on the right lower side of each seat allows for seat adjustment according to pilot size.

CANOPY

The cabin's canopy slides on wheel bearings along tracks located on fuselage sides; canopy is made out of composite material. Latching system uses a central lever located overhead and two additional levers positioned on canopy's sides. The canopy could be opened both from in and outside. In correspondence with each lock is present a placard indicating the emergency release procedure.

LUGGAGE COMPARTMENT

The Luggage compartment is located behind the pilots' seats. Luggage shall be uniformly distributed on utility shelf and its weight shall not exceed 20kg. Tie-down luggage using adjustable tie-down net.

WARNING

Before loading luggage, check aircraft's weight and CG location (see Sect. 6)

POWERPLANT

ENGINE

Manufacturer	Bombardier-Rotax GmbH
Model	ROTAX 912 S2
Type	4 stroke, horizontally-opposed 4 cylinder, mixed air and water cooled, twin electronic ignition, forced lubrication.
Maximum rating	98.6hp (73.5kW) @ 5800 rpm/min (2388 rpm/min. prop). Gear reduction ratio - 2.4286:1
Max oil consumption	Max: 0.1 litres/hour

PROPELLER

Manufacturer	Hoffmann Propeller
Model	HO17GHM A 174 177C
N° of blades	2
Diameter	1740 mm (no reduction permitted)
Type	wood, fixed pitch

FUEL SYSTEM

The system is equipped with two aluminium fuel tanks integrated within the wing leading edge and accessible for inspection through dedicated covers. Capacity of individual tank is 50lt and the total fuel capacity is 100lt. A multi-position fuel selector valve is located into the cabin. It is possible to select the following fuel feeding: LEFT (means a left tank feeding), RIGHT (means a right tank feeding) and a third OFF position which could not be accidentally operated. A strainer cup with a drainage valve (Gascolator) is located beneath the cabin, just behind the firewall. Fuel level indicators for each tank are located on instrument panel. Fuel feed is through an engine-driven mechanical pump and also through an electric pump that supplies adequate engine feed in case of main pump failure. Figure 7-3 illustrates the schematic layout of the fuel system.

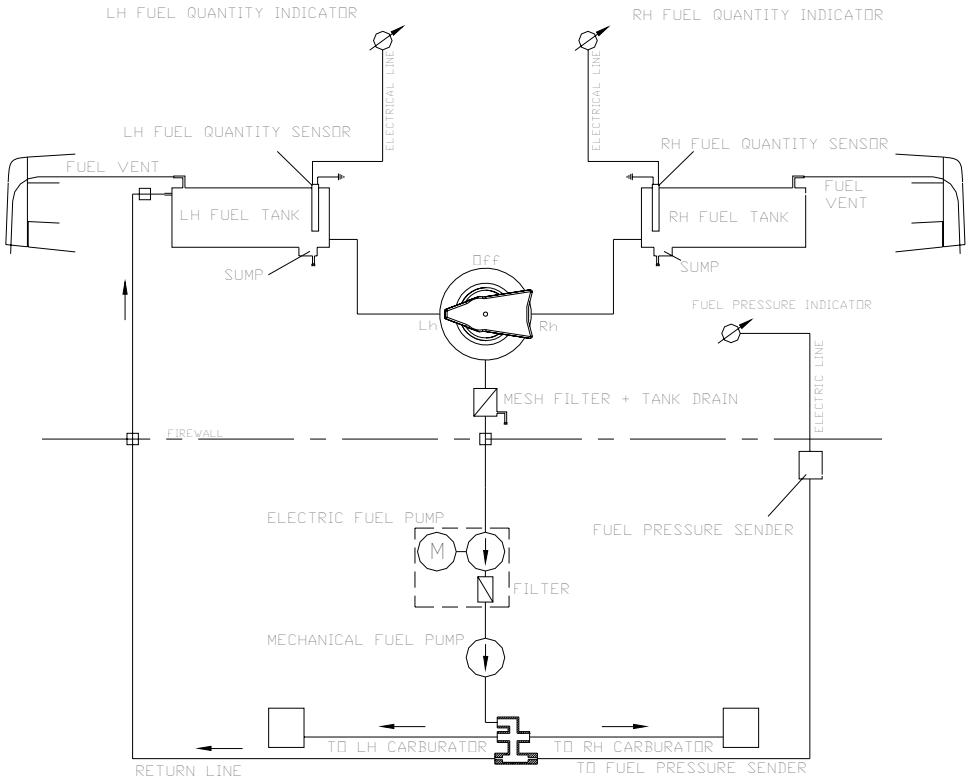

Fig.7-3. FUEL SYSTEM SCHEMATIC

ELECTRICAL SYSTEM

The aircraft's electrical system consists of a 12 Volt DC circuit controlled by the Master Switch located on the instrument panel. Electricity is provided by an alternator and by a buffer battery. Generator light is located on the right side of the instrument panel.

WARNING

If the Ignition is in the position L, R, or BOTH, an accidental movement of the propeller may start the engine with possible danger for bystanders.

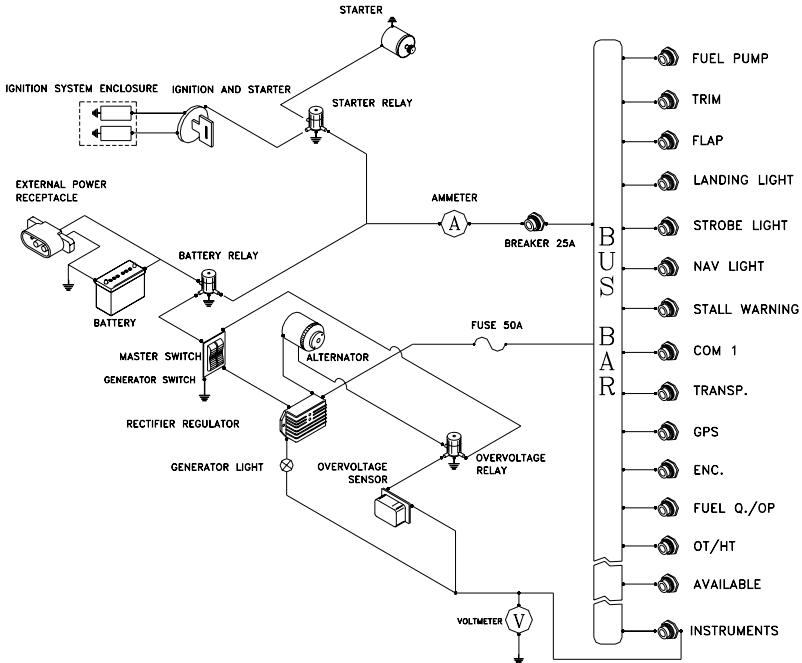

FIG.7-4. ELECTRICAL SYSTEM SCHEMATIC

GENERATOR LIGHT

Generator light (red coloured) illuminates either:

- for a generator failure.
- for a failure of the regulator/rectifier, with consequent overvoltage sensor shut off.

VOLTMETER AND AMMETER

The voltmeter indicates voltage on bus bar. A positive ammeter indication warns that the generator is charging the battery, a negative value indicates the battery's discharge rate.

OIL AND CYLINDER HEADS TEMP. - OIL PRESSURE

These instruments are connected in series with their respective sensors. The same breaker protects all temperature instruments while a second breaker protects oil pressure indicator and other instruments.

O.A.T. INDICATOR

A digital Outside Air Temperature indicator (°C) is located on the upper left side of the instrument panel.

STALL WARNING SYSTEM

The aircraft is equipped with a stall warning system consisting of a sensor located on the right wing leading edge connected to a warning horn located near the instrument panel.

AVIONICS

The central part of the instrument panel holds room for avionics equipment. The manufacturer of each individual system furnishes features for each system.

EXTERNAL POWER SUPPLY

On the right side of the tail cone, an external power is present. Using this device it is possible to feed the electric system directly on the bus bar, by an external power source. It should be used at the engine start-up in cold weather condition. For engine start below -17°C OAT it is advisable to use the external power source.

Follow this procedure to start the engine using the external power source.

1. Magnetos, Master switch, Generator switch: OFF
2. Open the receptacle door and insert the external power source's plug into the socket
3. Engine start-up procedure (see Sect. 4 in this manual)
4. Disconnect the external power source's plug and close firmly the receptacle door.

PITOT AND STATIC PRESSURE SYSTEMS

The airspeed indicator system for the aircraft is shown below.

Below the left wing's leading edge are positioned in a single group (1) both the Pitot tube (3, total pressure intake) and a series of static ports (6). Two flexible hoses (5) feed the airspeed indicator (4) on the instrument panel.

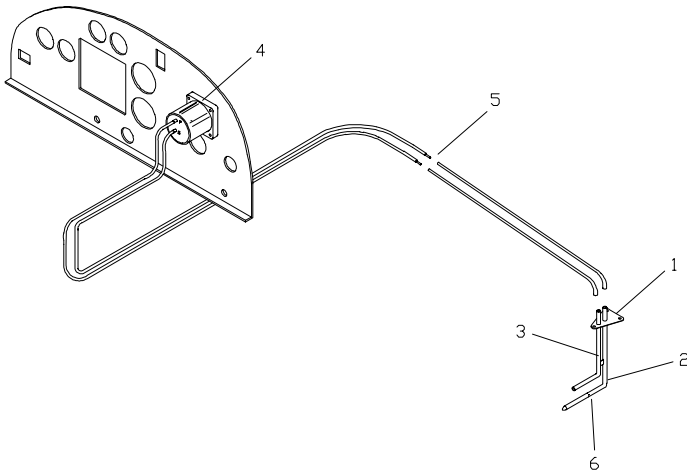

FIG.7-5. AIRSPEED INDICATOR SYSTEM

BRAKES

The aircraft's braking system is a single system acting on both wheels of main landing gear through disk brakes, the same circuit acts as parking brake via an intercept valve (2).

To activate brakes it is sufficient to verify that brake shut-off valve (2) positioned on tunnel between pilots is OFF, then activate brake lever (1) as necessary.

To activate parking brake pull brake lever (1) and set brake shut-off valve (2) to ON.

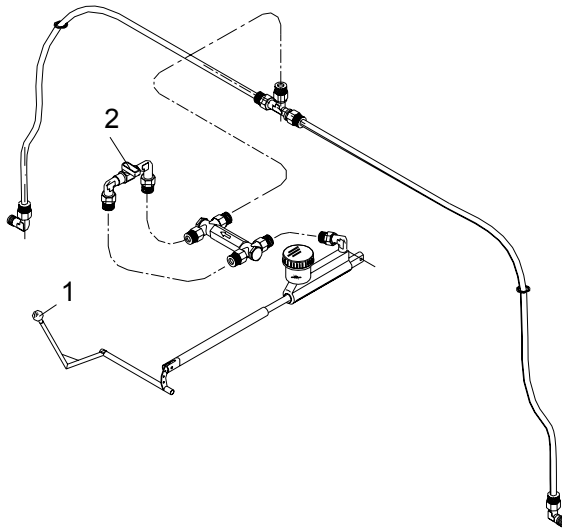

FIG. 7-6. BRAKE SYSTEM

INTENTIONALLY LEFT BLANK

SECTION 8

GROUND HANDLING & SERVICE

TABLE OF CONTENTS

INTRODUCTION.....	2
AIRCRAFT INSPECTION PERIODS.....	2
AIRCRAFT ALTERATIONS OR REPAIRS	2
GROUND HANDLING.....	2
CLEANING AND CARE.....	3

INTRODUCTION

This section contains factory-recommended procedures for proper ground handling and routine care and servicing. It also identifies certain inspection and maintenance requirements, which must be followed if the aircraft is to retain its new-plane performance and dependability. It is recommended to follow a planned schedule of lubrication and preventive maintenance based on climatic and flying conditions encountered locally.

AIRCRAFT INSPECTION PERIODS

Inspection intervals occur at 100 hours and in accordance with special inspection schedules which are added to regularly scheduled inspections. Correct maintenance procedures are described in the aircraft's Maintenance Manual or in the engine's Maintenance Manual.

AIRCRAFT ALTERATIONS OR REPAIRS

It is essential that the responsible Airworthiness Authority be contacted prior to any alterations on the aircraft to ensure that airworthiness of the aircraft is not violated. For repairs, refer to aircraft's Maintenance Manual.

GROUND HANDLING

TOWING

The aircraft is most easily and safely maneuvered by pulling it by its propeller near the axle. Aircraft may be steered by turning rudder or, for steep turns, by pushing lightly on tailcone to lift nose wheel.

PARKING AND TIE-DOWN

When parking airplane outdoors, head it into the wind and set the parking brake. If chocks or wedges are available it is preferable to use the latter.

In severe weather and high wind conditions it is wise to tie the airplane down. Tie-down ropes shall be fastened to the lug present on the wing's lower surface. Nose gear fork can be used for front tie-down location.

Flight controls shall be secured to avoid possible weathervaning damage to moving surfaces.

JACKING

Given the light empty weight of the aircraft, lifting one of the main wheels can easily be accomplished even without the use of hydraulic jacks. For an acceptable procedure please refer to the Maintenance Manual.

LEVELING

Aircraft leveling may become necessary to check wing incidence, dihedral or the exact location of CG. Longitudinal leveling verification is obtained placing a level between the front and aft seat's supporting trusses (slide off the seats to get the access to the two trusses).

ROAD TRANSPORT

It is recommended to secure tightly all aircraft components onto the cart to avoid damage during transport. Minimum cart size is 7x2.5 meters. It is suggested to place wings under the aircraft's bottom, secured by specific clamps. Secondary components like the stabilator shall be protected from accidental hits using plastic or other material. For correct rigging and de-rigging procedure, refer to the Maintenance Manual.

CLEANING AND CARE

To clean painted surfaces, use a mild detergent such as shampoo normally used for car finish; use a soft cloth for drying

The plastic windshield and windows should never be dusted when dry; use lukewarm soapy water and dry using chamois only. It is possible to use special glass detergents but, in any case, never use products such as gasoline, alcohol, acetone or other solvents.

To clean cabin interior, seats, upholstery and carpet, it is generally recommended to use foam-type detergents.

LEFT INTENTIONALLY BLANK

SECTION 9

SUPPLEMENTS

TABLE OF CONTENTS

SUPPLEMENT N° 1: GARMIN GNS 430 GPS/VHF COMM/NAV (5 PAGES)

INTRODUCTION.....	2
1.1 GENERAL	2
1.2 LIMITATIONS	3
1.3 EMERGENCY PROCEDURES	4
1.4 NORMAL OPERATION	4
1.5 PERFORMANCE	5
1.6 WEIGHT AND BALANCE.....	5
1.7 SYSTEMS.....	5

SUPPLEMENT N° 1

GARMIN GNS 430 GPS/VHF COMM/NAV

INTRODUCTION

This section contains supplementary information for safe and efficient operation of the aircraft if equipped with a Garmin GNS 430 system.

1.1 GENERAL

1. The GPS GNS 430 Global Positioning System is an integrated system that contains a GPS navigation system in addition to a VHF COMM radiotransceiver and a VOR/ILS receiver.
2. The system includes an antenna for GPS, a receiver for GPS, a VOR/LOC antenna, a VOR/ILS receiver, a VHF Comm antenna and a VHF Comm transceiver.
3. The main function of the VHF Comm is to allow communication with the control tower.
4. The VOR/ILS function is to receive and demodulate VOR and LOC signals.
5. The GPS section is dedicated to signal acquisition from the GPS satellite system and to furnish real-time information with respect to position, speed and time.
6. With appropriate signals the GPS GNS 430 can:
 - plan VFR/IFR routes, track waypoints and plan non-precision instrument approaches (GPS, LORAN-C, VOR, VOR-DME, TACAN, NDB, NDB-DME, RNAV) in accordance with AC 20-138;
7. Reference coordinates used for navigation are WGS-84.

1.2 LIMITATIONS

1. The “Pilot’s guide and Reference” p/n 190-00140-00 rev. F dated July 2000 or later versions, must be available for proper use of the instrument.
2. Only VFR use is permitted.
3. The GPS section must use the following (or more recently approved) software versions:

<i>Subsystem</i>	<i>Software version</i>
MAIN	2.00
GPS	2.00
COMM	1.22
VOR/LOC	1.25

The software version of the main subsystem is displayed by the GNS 430 immediately after start-up for 5 seconds. Remaining subsystems software versions may be verified in sub-page 2 of the AUX Group display for “SOFTWARE/DATA BASE VER”.

4. The following default settings must be keyed-in in the **SETUP 1** menu of the GNS430 receiver before any other operation:
 - **DIS, SPD** *nm kt* (select navigation unit to “nautical miles” and “knots”);
 - **ALT, VS** *ft fpm* (select altitude to “feet ” and “feet per minute”);
 - **MAP DATUM** *WGS 84* (select map datum WGS84);
 - **POSN** *deg-min* (select grid for nav unit to decimal-minutes);

1.3 EMERGENCY PROCEDURES

1. If the information provided by the Garmin GNS430 is not available or manifestly wrong, it is necessary to use other navigation instruments.
2. If the message “WARN” appears in the lower left portion of the display, the receiver cannot be considered useful as a navigation aid. The pilot must use the VLOC receiver or an alternative navigation system.
3. If the message “INTEG” appears in the lower left portion of the display, the RAIM function is unavailable. The pilot must use the VLOC receiver or an alternative navigation system;
4. In emergency flight conditions, pressing the COM flip-flop knob for 2 seconds will automatically tune-in the 121.500MHz emergency frequency.

1.4 NORMAL OPERATION

1. DETAIL FOR NORMAL OPERATION

Normal operation is described in the “Pilot’s guide and Reference” P/N 190-00140-00 rev. F dated July 2000 or later versions.

2. GARMIN GNS 430 DISPLAY.

Data for GNS 430 system appears on GARMIN GNS430 display.

Data source is either the GPS or the VLOC as indicated above the CDI switch of the GARMIN 430 display.

1.5 PERFORMANCE

No variations.

1.6 WEIGHT AND BALANCE

See section 6 of the present manual.

1.7 SYSTEMS

See “GNS 430 Pilot’s Guide” p/n 190-00140-00 rev. F dated July 2000 or later versions, for a complete description of the system.

LEFT INTENTIONALLY BLANK